

Dynamics of Haptic and Teleoperation Systems

Jee-Hwan Ryu

School of Mechanical Engineering
Korea University of Technology and Education

Teleoperation System Overview

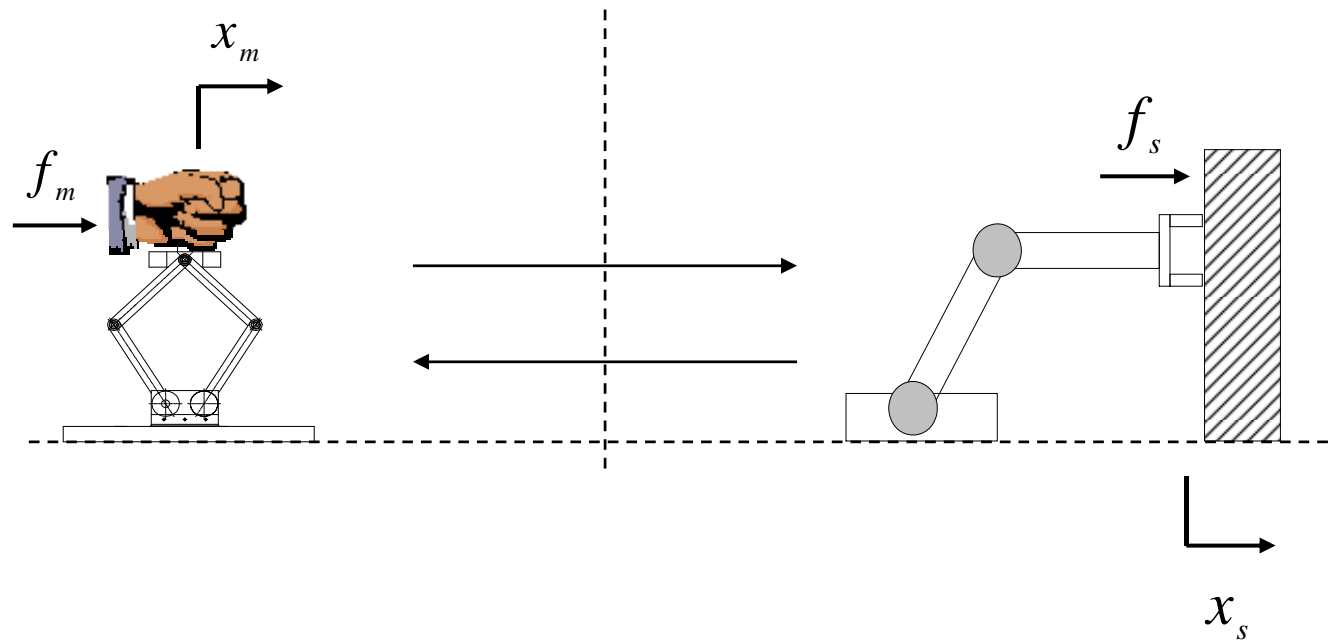

Dynamic Model of Teleoperation Systems

1. Mechanical Model
2. Mechanical and Electrical Analogy
3. Electrical Model
4. Understanding of the behavior of Teleoperation Systems

One-DOF Schematic Diagram

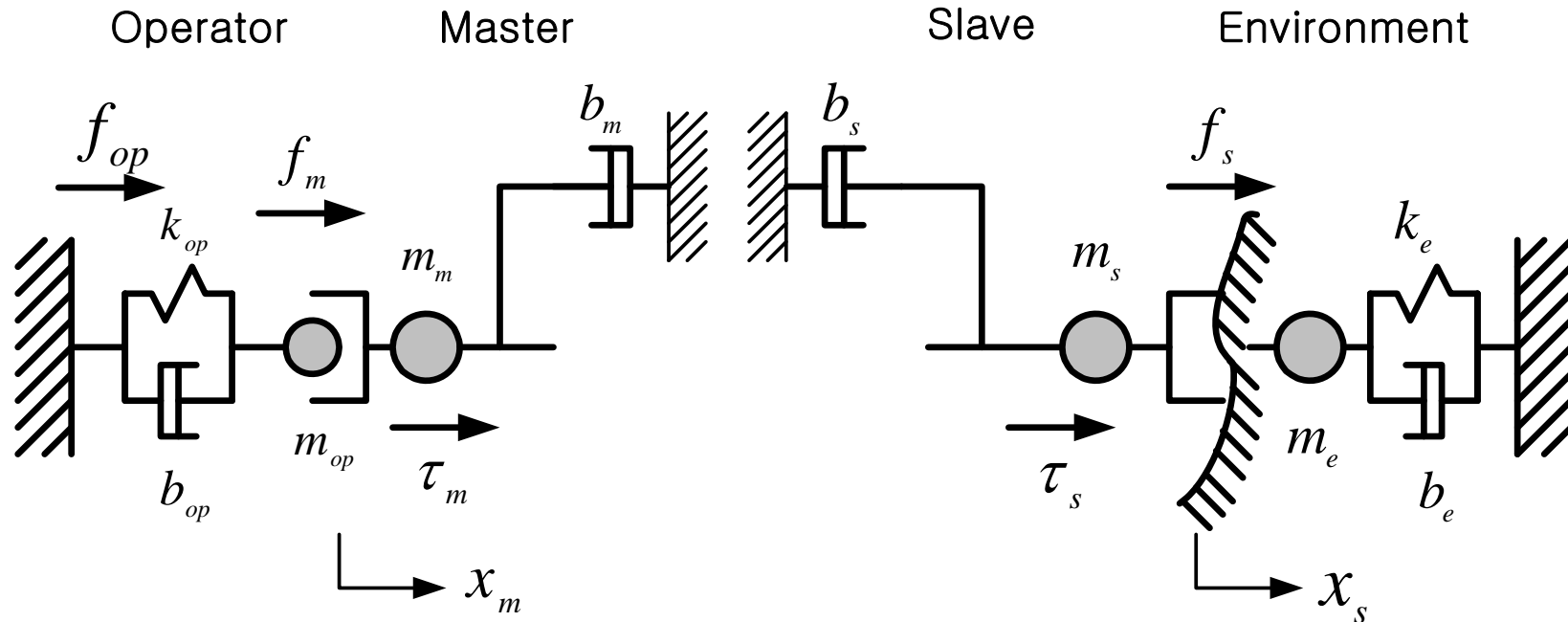

The dynamics of the master arm and slave arm is given by the following equations

$$\text{Master: } m_m \ddot{x}_m + b_m \dot{x}_m = \tau_m + f_m$$

$$\text{Slave: } m_s \ddot{x}_s + b_s \dot{x}_s = \tau_s - f_s$$

Definition of Parameters

$$\text{Master : } m_m \ddot{x}_m + b_m \dot{x}_m = \tau_m + f_m$$

$$\text{Slave : } m_s \ddot{x}_s + b_s \dot{x}_s = \tau_s - f_s$$

x_m : displacement of master arm

x_s : displacement of slave arm

m_m : mass coefficient of the master arm

b_m : viscous coefficient of the master arm

m_s : mass coefficient of the slave arm

b_s : viscous coefficient of the slave arm

f_m : force that the operator applies to the master arm

f_s : force that the slave arm applies to the environment

τ_m : actuator driving forces of master

τ_s : actuator driving forces of slave

Dynamics of the Environment

The dynamics of the environment interacting with the slave arm is modeled by the following linear system:

$$f_s = m_e \ddot{x}_s + b_e \dot{x}_s + k_e x_s$$

where

m_e : mass coefficient of the environment

b_e : damping coefficient of the environment

k_e : stiffness coefficient of the environment

The displacement of the object is represented by x_s because the slave arm is assumed to be rigidly attached with the environments or slave arm firmly grasping the environments, in such a way that it may not depart from the object, once the slave arm contact the environments.

Dynamics of the Operator

It is also assumed that the dynamics of the operator can be approximately represented as a simple spring-damper-mass system

$$f_{op} - f_m = m_{op} \ddot{x}_m + b_{op} \dot{x}_m + k_{op} x_m$$

where

m_{op} : mass coefficient of the operator

b_{op} : damping coefficient of the operator

k_{op} : stiffness coefficient of the operator

f_{op} : force generated by the operator's muscles

The displacement of the operator is represented by x_m because it is assumed that the operator is firmly grasping the master arm and operator never releases the master arm during the operation.

Master/Operator Cooperative System

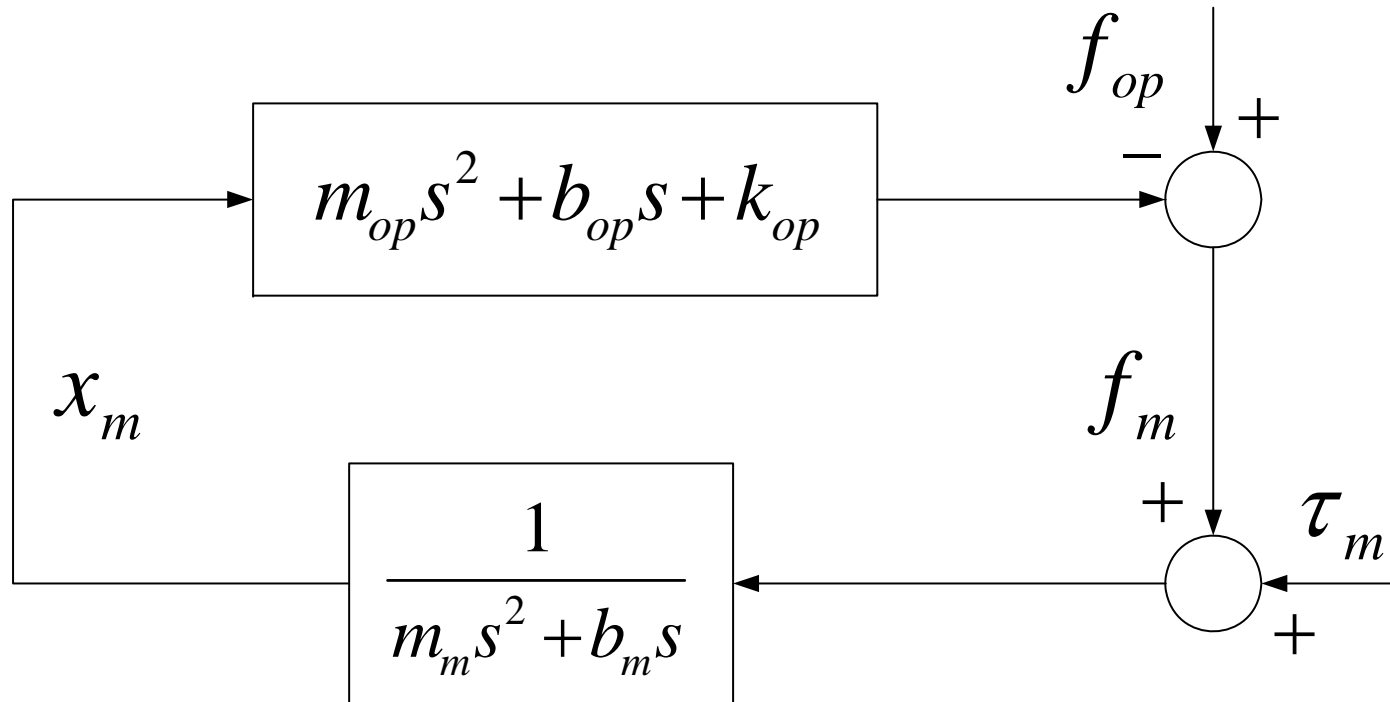

Slave/Environment Cooperative System

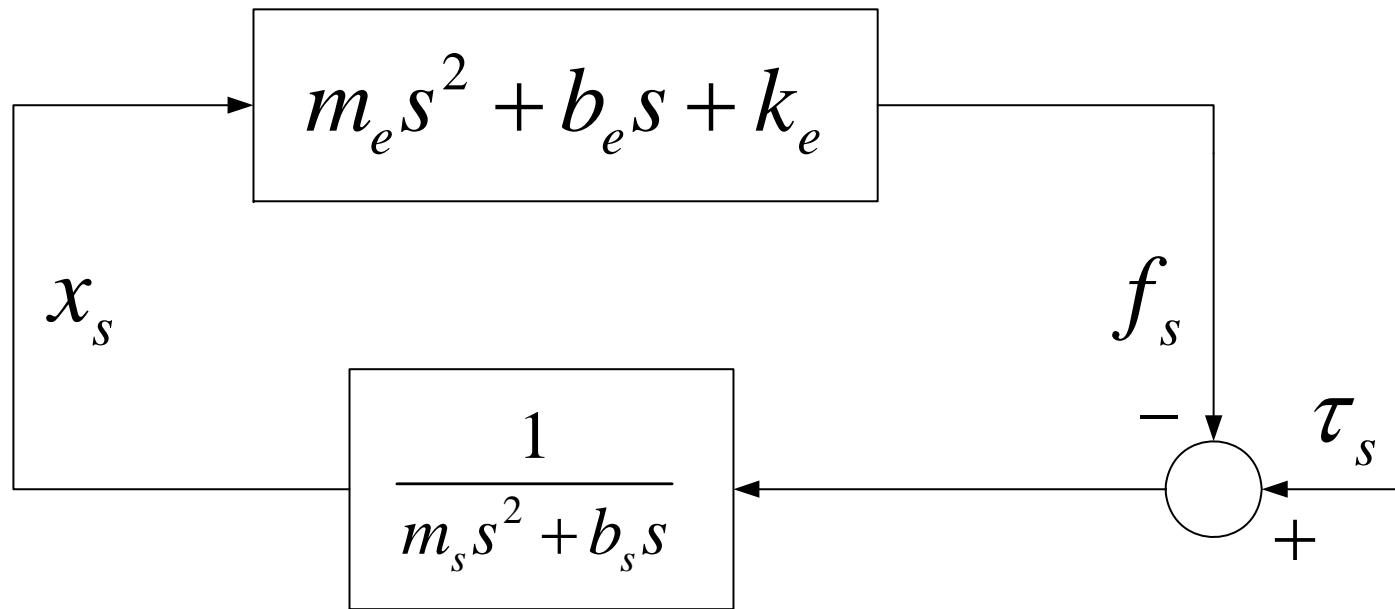

Total System

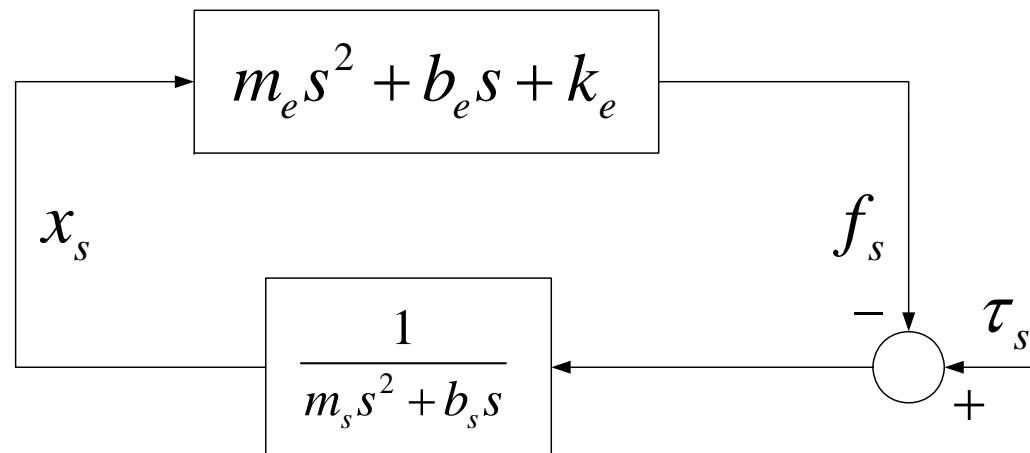
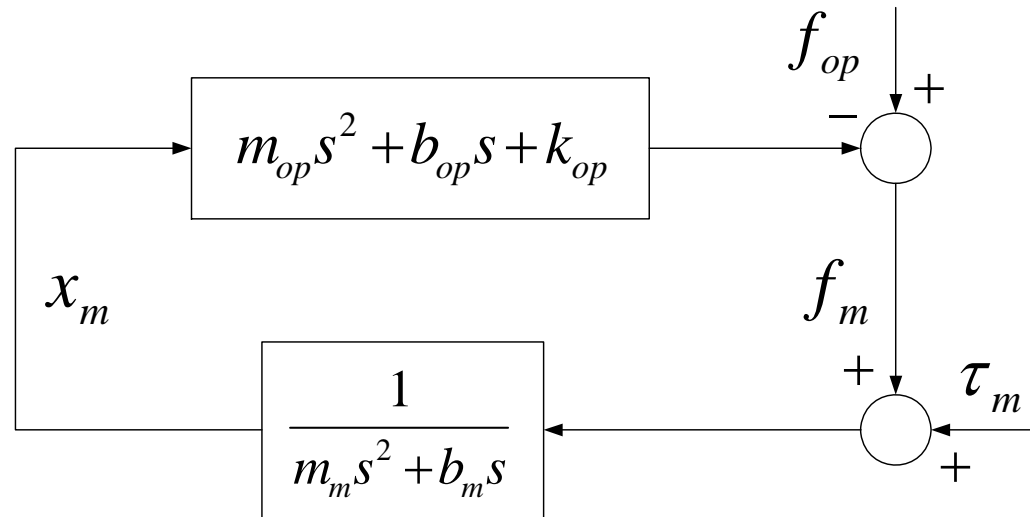

Let's Do This

- Simulate dynamics behavior
- How to make stable simulation ?

“Y. Yokokohji and T. Yoshikawa, “Bilateral Control of Master-slave Manipulators for Ideal Kinesthetic Coupling-Formulation and Experiment,” *IEEE Trans. Robotics and Automation*, Vol. 10, No. 5, pp. 605-620, 1994.”

Constitutive Relation

The environment defines a “constitutive relation,” a relation between force and position or one of its derivatives.

Examples:

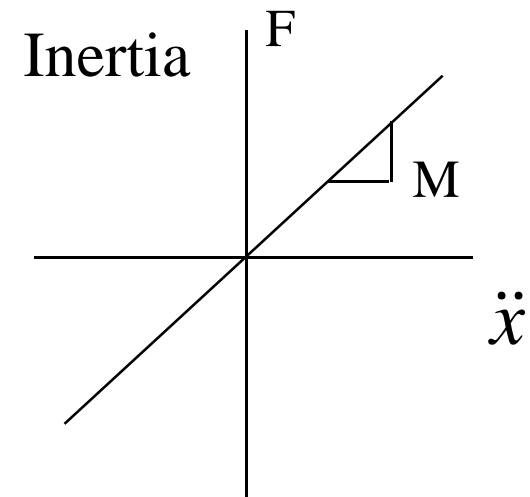
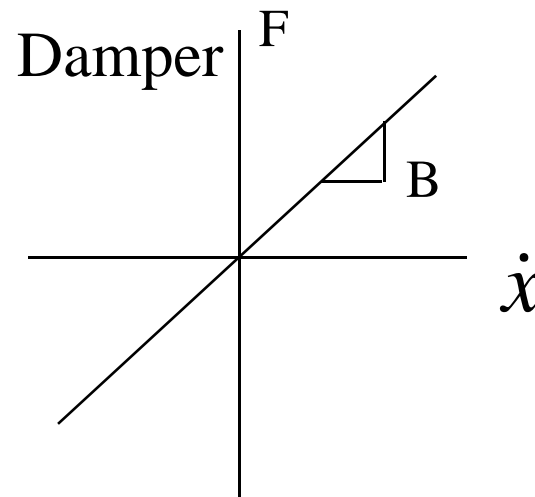
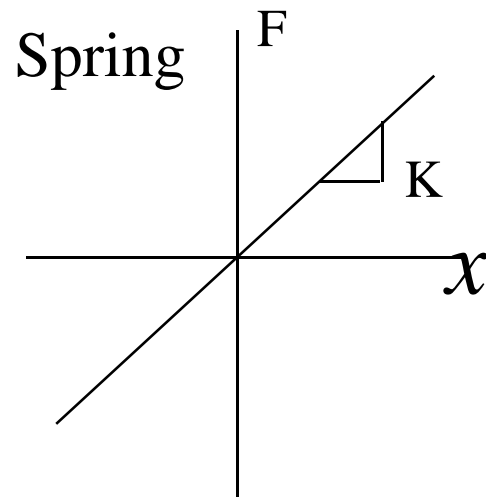

Electrical Analogy

These relations for mechanical systems are directly analogous to similar relations for electrical systems

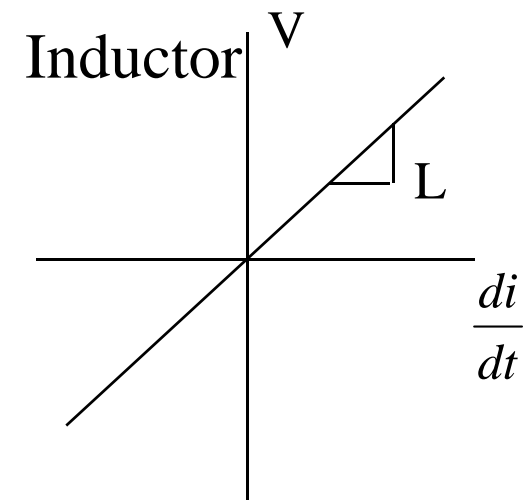
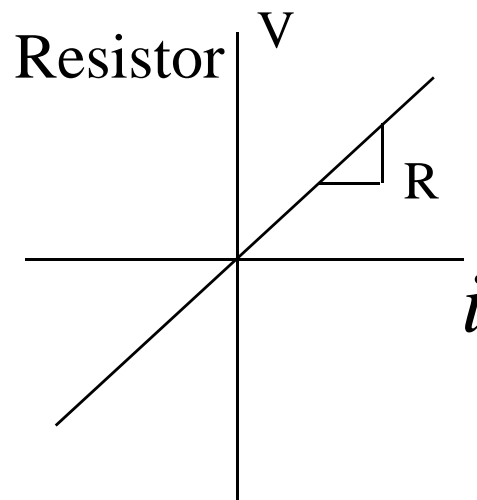
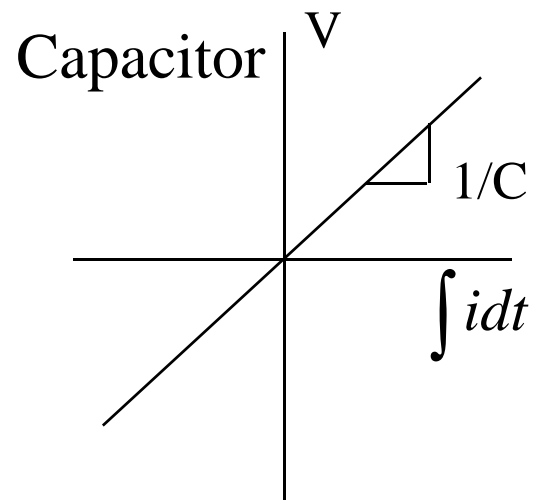

Force \longleftrightarrow Voltage (effort)
Velocity \longleftrightarrow Current (flow)

Example 1

Convert an environment defined by the mechanical system

$$F = m\ddot{x} + b\dot{x} + kx$$

to the equivalent electrical circuit.

We can make the substitutions

$$V \leftrightarrow F, \quad i \leftrightarrow \dot{x}$$

giving

$$V = m \frac{di}{dt} + bi + k \int_0^t i dt$$

The parameters m , b , k correspond to the electrical parameters

$$m \leftrightarrow L, \quad b \leftrightarrow R, \quad k \leftrightarrow \frac{1}{C}$$

Example 1

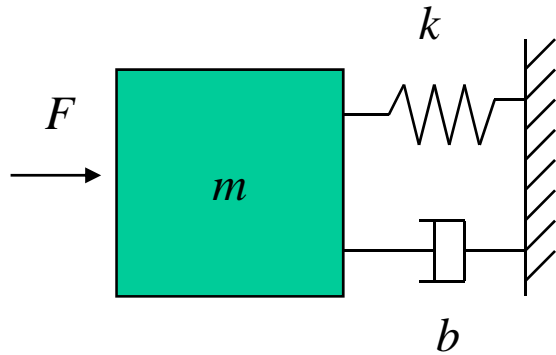

$$F = m\ddot{x} + b\dot{x} + kx$$

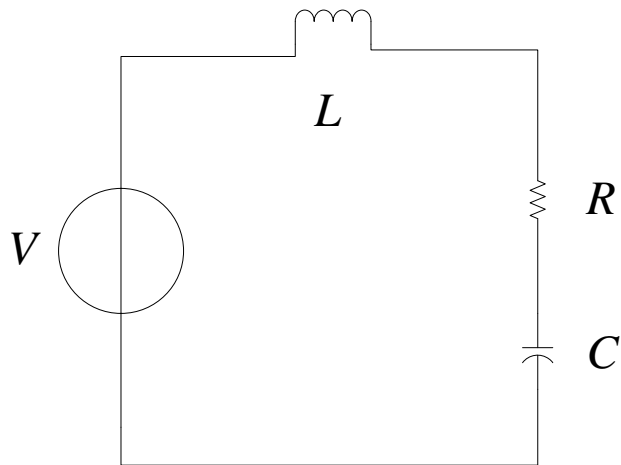

$$V = m \frac{di}{dt} + bi + k \int_0^t i dt$$

Mechanical to Electrical and vice versa

Consider two equations which correspond physical laws:

$$\sum F = 0, \text{ Point mass}$$

$$\sum \dot{x} = 0, \text{ mechanical loop}$$

The analogous electrical laws are

$$\sum V = 0, \text{ electrical loop}$$

$$\sum i = 0, \text{ circuit node}$$

We **MUST** equate a point mass with an electrical loop and circuit node with a mechanical loop. In other words, we must map series mechanical connections to parallel electrical ones and vice versa.

Example 2

Convert the following mechanical system to an equivalent electrical network:

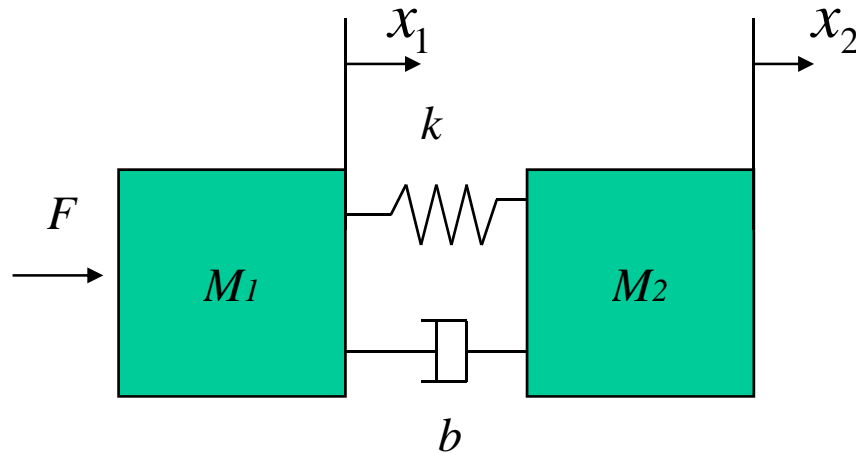

1) point mass = electrical loop

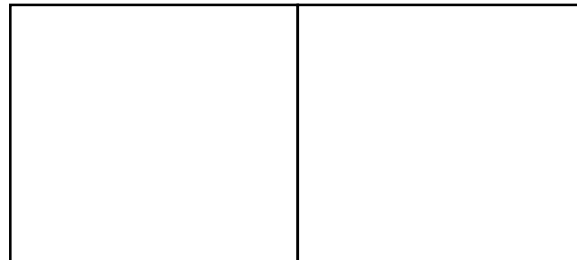

Example 2

2) A force generator is connected to the first mass. Thus we insert a voltage source in the first loop:

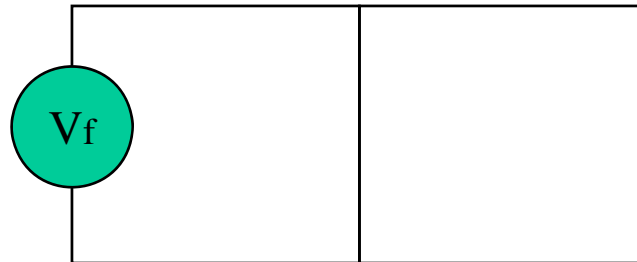

3) M_1 , M_2 correspond to inductors. Each inductor should have a current which corresponds to the correct velocity therefore:

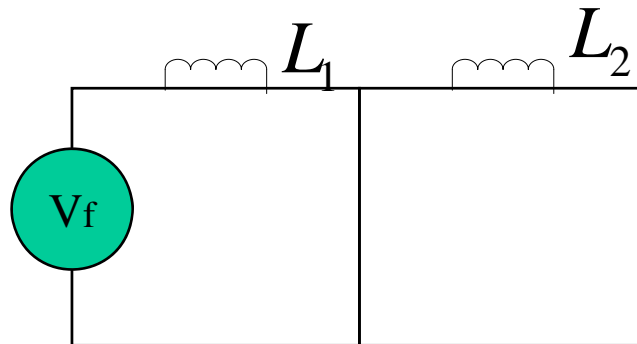

Example 2

4) b, k , are connected to both masses. The velocity/position which determines their forces is the difference between the two masses' velocities. They thus correspond to resistance and capacitance connected into the common branch of the two loops since

$$\dot{x}_2 - \dot{x}_1 \rightarrow i_2 - i_1$$

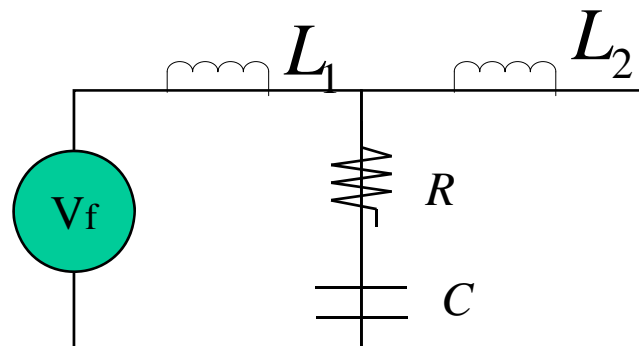

where $R=b$, and $C=1/K$

Example 3: Contact

- Discontinuous contact is harder to model, but more important since contact always begins with an impact between the robot and environment. Consider a robot which is predominantly an inertia. Contact with a rigid wall could be modeled by a switch:

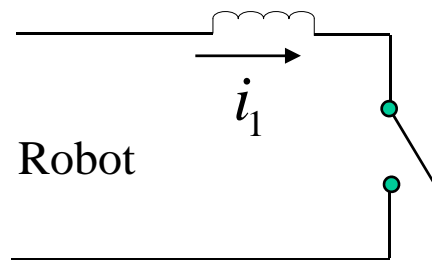

open : Contact $\rightarrow i_1 = 0$

closed : free motion $\rightarrow i_1 \neq 0$

Example 3: Contact

or, for a non-rigid environment:

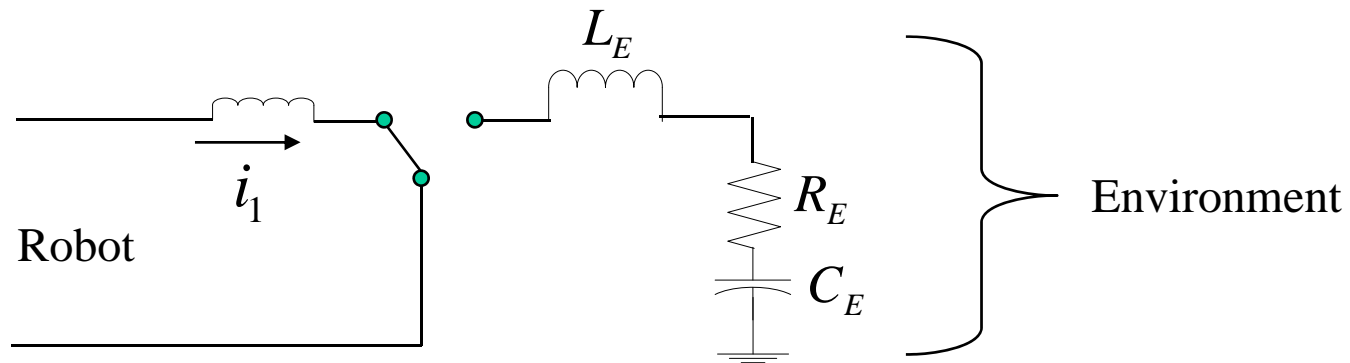

The switch can be controlled by the position: $\int_0^t i_1(t) dt$

Electrical Conversion

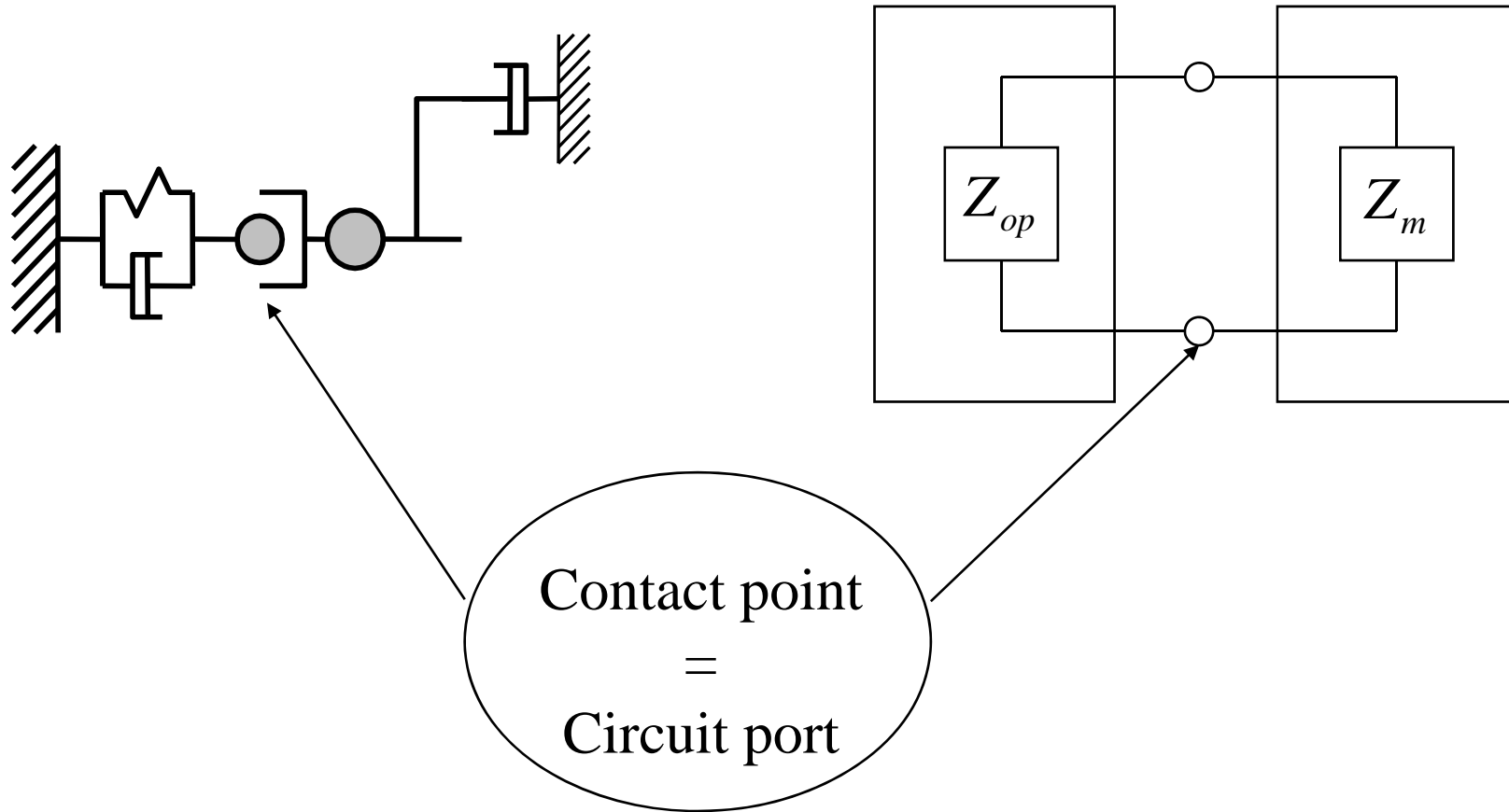

Two-port Network

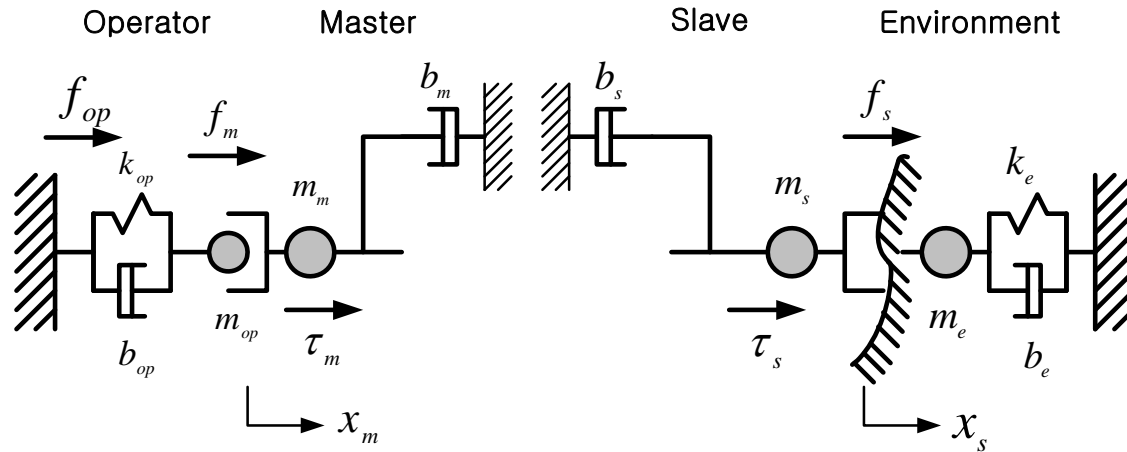

Teleoperation system have two-contact point
Thus, two-circuit port

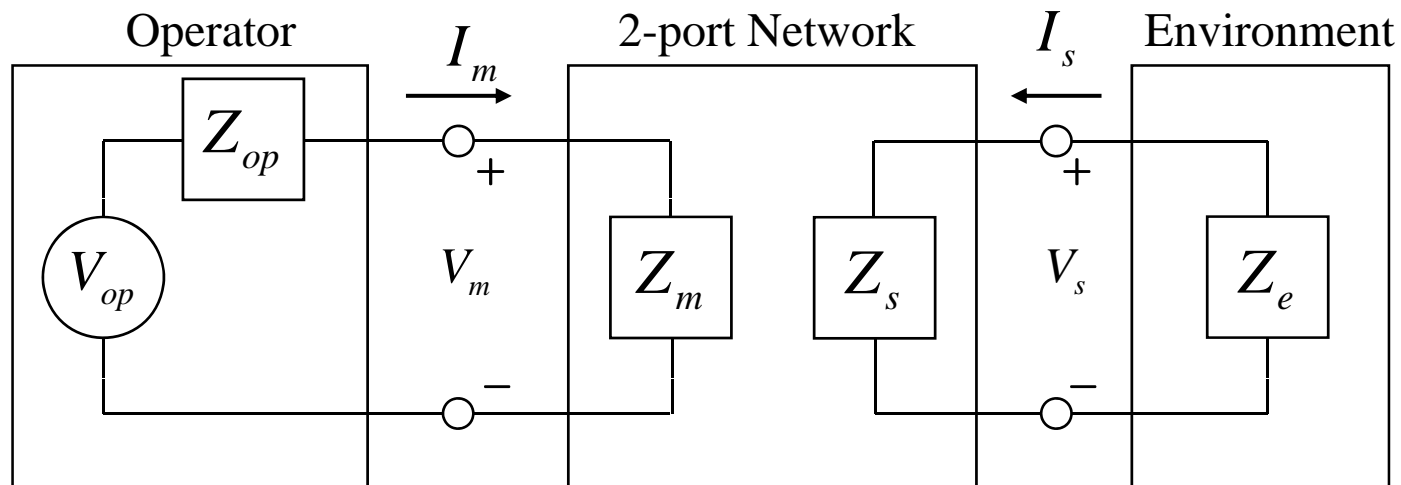

Correspondence btw. Mech. Elec.

velocity of the master arm	\dot{x}_m	\leftrightarrow	current	I_m
velocity of the slave arm	$-\dot{x}_s$	\leftrightarrow	current	I_s
operator's force	f_{op}	\leftrightarrow	voltage	V_{op}
force at the master side	f_m	\leftrightarrow	voltage	V_m
force at the slave side	f_s	\leftrightarrow	voltage	V_s

Two-port Mapping

The relationship between efforts and flows is commonly described in terms of an immittance matrix (P).

Immittance mapping : $y = Pu$

Impedance matrix

$$\begin{bmatrix} f_m \\ f_s \end{bmatrix} = \begin{bmatrix} z_{11} & z_{12} \\ z_{21} & z_{22} \end{bmatrix} \begin{bmatrix} v_m \\ -v_s \end{bmatrix}$$

Admittance matrix

$$\begin{bmatrix} v_m \\ -v_s \end{bmatrix} = \begin{bmatrix} y_{11} & y_{12} \\ y_{21} & y_{22} \end{bmatrix} \begin{bmatrix} f_m \\ f_s \end{bmatrix}$$

Hybrid matrix

$$\begin{bmatrix} f_m \\ -v_s \end{bmatrix} = \begin{bmatrix} h_{11} & h_{12} \\ h_{21} & h_{22} \end{bmatrix} \begin{bmatrix} v_m \\ f_s \end{bmatrix}$$

Alternate hybrid matrix

$$\begin{bmatrix} v_m \\ f_s \end{bmatrix} = \begin{bmatrix} g_{11} & g_{12} \\ g_{21} & g_{22} \end{bmatrix} \begin{bmatrix} f_m \\ -v_s \end{bmatrix}$$

All of the immittance mapping satisfy the following condition

$$y^T u = f_m v_m - f_s v_s$$

Hybrid Parameter Interpretation

$$h_{11} = \left. \frac{V_m}{I_m} \right|_{V_s=0} \Leftrightarrow \left. \frac{f_m}{v_m} \right|_{f_s=0} \Leftrightarrow \text{Free motion input impedance}$$

$$h_{12} = \left. \frac{V_m}{V_s} \right|_{I_s=0} \Leftrightarrow \left. \frac{f_m}{f_s} \right|_{v_s=0} \Leftrightarrow \text{Force feedback gain } \lambda_f$$

$$h_{21} = \left. \frac{I_s}{I_m} \right|_{V_s=0} \Leftrightarrow \left. \frac{v_s}{v_m} \right|_{f_s=0} \Leftrightarrow \text{Forward velocity gain } -\lambda_p$$

$$h_{22} = \left. \frac{I_s}{V_s} \right|_{I_m=0} \Leftrightarrow \left. \frac{v_s}{f_s} \right|_{v_m=0} \Leftrightarrow \text{Output admittance w/ clamped input}$$

$$\mathbf{H} = \begin{bmatrix} \mathbf{Z}_{In} & \lambda_f \\ -\lambda_p & 1/\mathbf{Z}_{Out} \end{bmatrix}$$

Dynamic Model of Haptic Interfaces

1. Mechanical Model
2. Electrical Model
3. Discrete Model with ZOH

Haptic Interaction System Overview

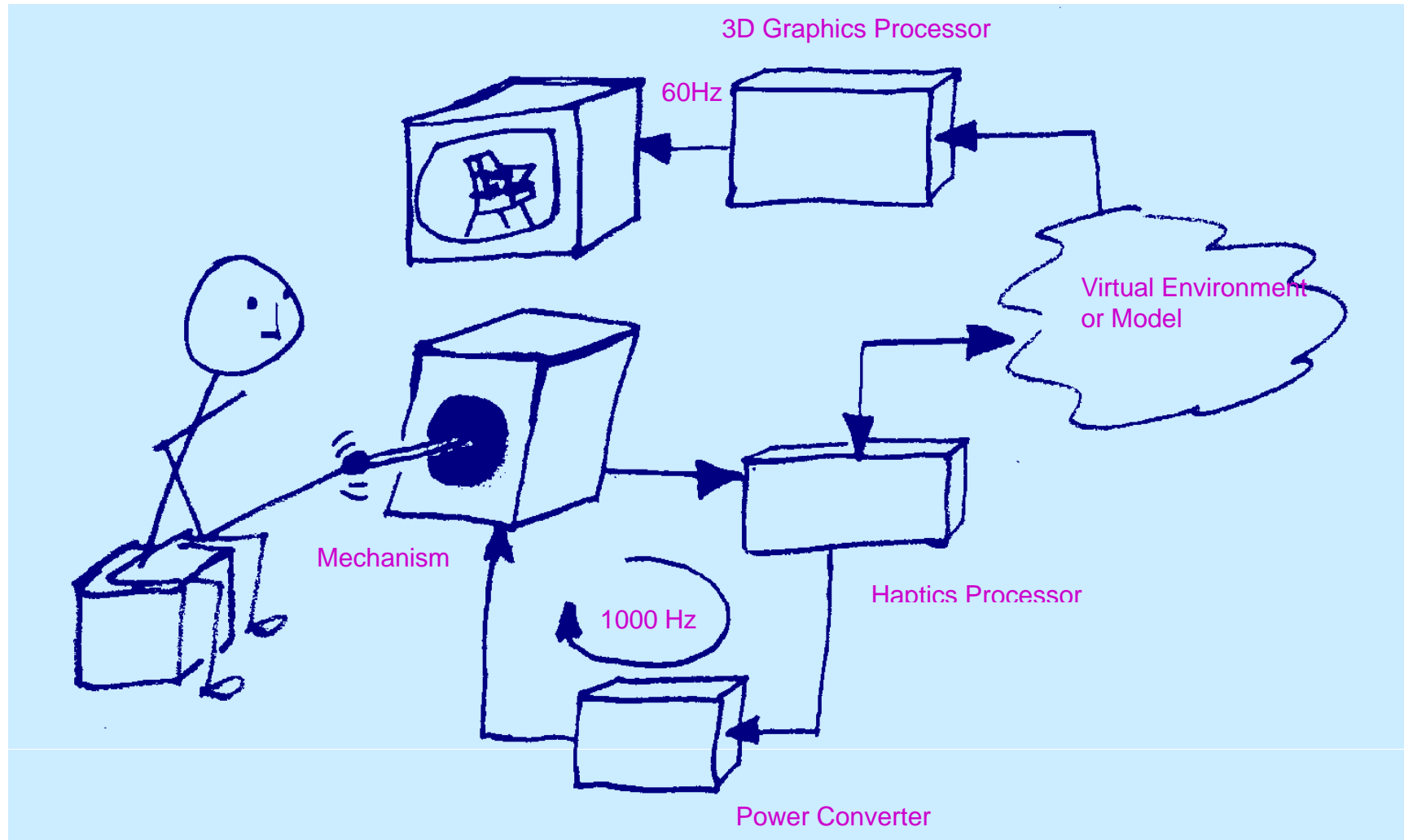

Mechanical and Electrical Model

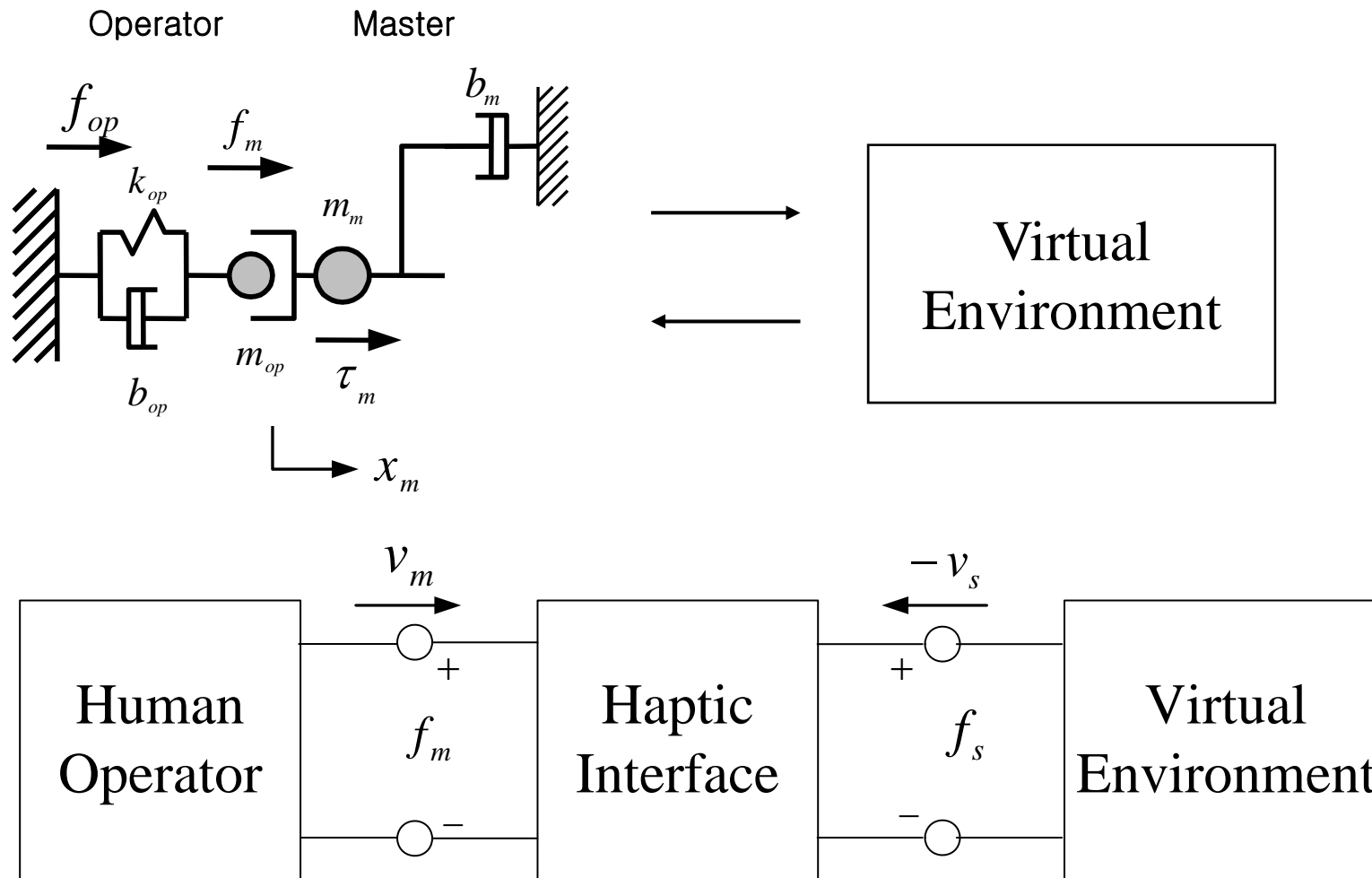

Mechanical Model

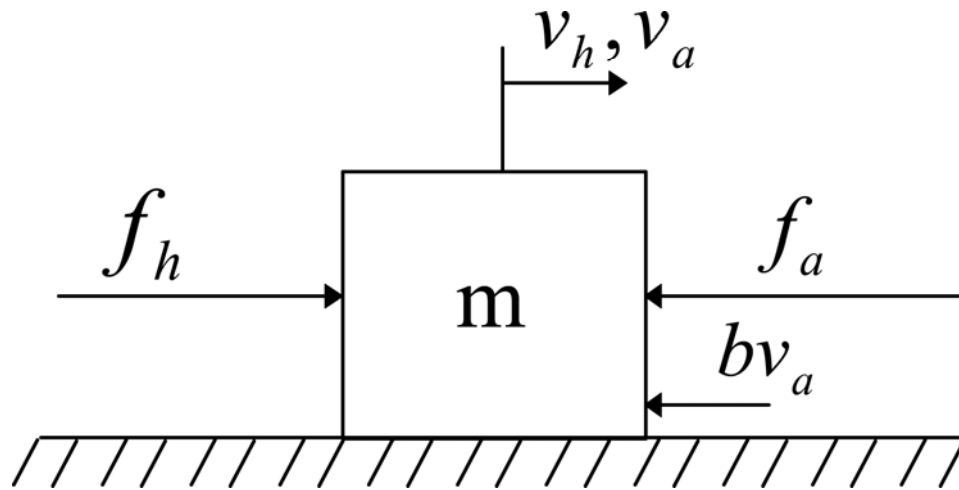

$$m\dot{v}_a + bv_a = f_h - f_a, \quad v_a = v_h$$

$$\begin{bmatrix} f_h \\ -v_a \end{bmatrix} = \begin{bmatrix} ms + b & 1 \\ -1 & 0 \end{bmatrix} \begin{bmatrix} v_h \\ f_a \end{bmatrix}$$

Discrete Model with ZOH

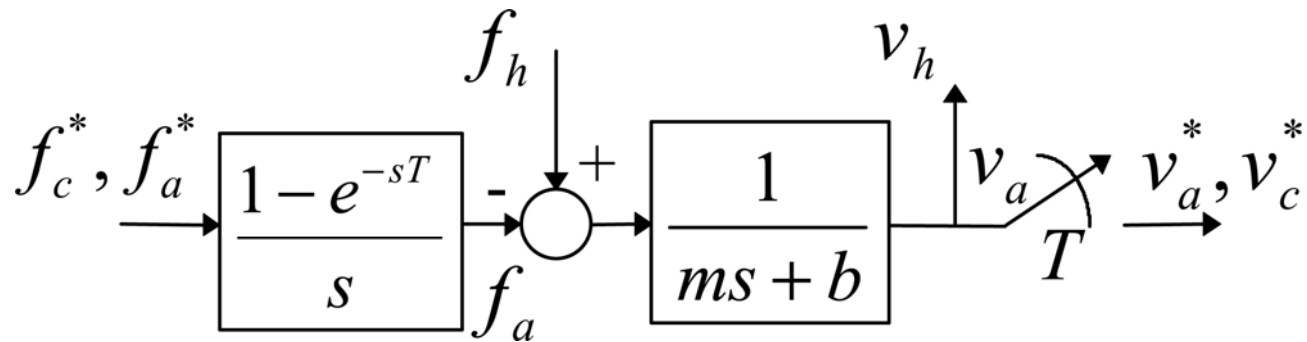

$$Z_d(z) = (ms + b) \Big|_{s \rightarrow \frac{2}{T} \left(\frac{z-1}{z+1} \right)} \quad ZOH(z) = \frac{1}{2} \frac{(z+1)}{z}$$

$$\begin{bmatrix} f_h \\ -v_c^* \end{bmatrix} = \begin{bmatrix} Z_d(z) & ZOH(z) \\ -1 & 0 \end{bmatrix} \begin{bmatrix} v_h \\ f_c^* \end{bmatrix}$$