

# Bilateral Control with Time Domain Passivity Approach Under Time-varying Communication Delay

Jee-Hwan Ryu

School of Mechanical Engineering, Korea University of Technology and Education,  
Cheonan, R. of Korea, jhryu@kut.ac.kr

**Abstract**—Recently, two-port time-domain passivity approach was modified for time-varying communication delay. The newly proposed approach could achieve stable teleoperation even under the serious time-varying delay and packet loss communication condition. However, after some operation hour, the accumulated energy difference between the input energy from one port and the output energy at the other port caused unstable behavior until the passivity controller is activated. Resetting scheme is introduced for solving this problem, and stable bilateral teleoperation can be guaranteed without worrying about the accumulated energy difference.

## I. INTRODUCTION

Teleoperation is one of the first domain of robotics and has been one of the most challenging issue [17]. In teleoperation, a human operator conducts a task in a remote environment via master and slave manipulators. With the progress of computer network, teleoperation is getting considerable attention again [3] because of its potential applications including tele-surgery, tele-maintenance and welfare.

When a robot is operated remotely by use of a teleoperator, force feedback can considerably improve an operator's ability to perform complex tasks by kinesthetically coupling the operator to the environment. However, any data communication over the computer network has communication time-delay. In the presence of communication time-delay, even though it is small, force feedback has strong destabilizing effect [16].

There have been numerous research for solving the time-delay problem in bilateral control of teleoperators. Based on the scattering theory, Anderson and Spong [1] proposed a bilateral control law that maintains stability under the communication time-delay. Niemeyer and Slotine [7] extended this idea, and introduced the notion of "wave variable". Even the wave variable method was successful, it assumed constant time-delay. Several approaches extended the original wave variable method to the case when there is time-varying communication delay [5], [8], [20].

There were also several other approaches. Leung [6] proposed a bilateral controller for time-delay based on the  $H_\infty$  optimal controller and  $\mu$ -synthesis frameworks. Oboe and Fiorini [9] dealt with the time-varying delay problem over the internet by using a simple PD-type controller. Sano [15] proposed a gain-scheduled  $H_\infty$  controller using measured time-delay.

However, the problem of previous approaches was the conservatism. The passivity was guaranteed with the expense of too much degradation of the system performance. For

solving this performance and stability issue Hannaford and Ryu have proposed a new concept of energy based approach. They proposed "Passivity Observer" (PO) for a network system to check the passivity, and "Passivity Controller" (PC), which is a time-varying damping element, to make a network system passive by dissipating only the required amount of energy. This idea has been successfully applied for guaranteeing the passivity of haptic [4] and teleoperation systems with no communication time-delay [10]. Recently this idea has been extended for stable bilateral control of teleoperators including time-varying communication delay [14].

In our previous paper, teleoperation experiments with about 120 (msec) of time-varying delay each way have been performed, and the newly proposed controller has achieved stable teleoperation in free motion and hard contact as well. However, we found a sort of unstable behavior when there is a big energy difference between the input energy at one port and the output energy at the other port until this energy difference is disappeared. In this paper, resetting scheme is introduced for escaping this big energy difference. The performance of the proposed resetting scheme is proved under serious time-varying delay and data packet loss communication condition.

## II. TWO-PORT TIME DOMAIN PASSIVITY APPROACH CONSIDERING TIME-VARYING COMMUNICATION DELAY

In this Section, recently modified two-port time-domain passivity approach [14], considering time-varying communication delay, is reviewed.

The basic idea of the modified approach is that we can separate the input and output energy at each port based on the sign of the product of the force and velocity at each port.

$$E_{obsv}(k) = E_{in}(k) - E_{out}(k) \quad (1)$$

Note that  $k$  means the  $k$ 'th step sampling time ( $t_k$ ).

If the sign of the product at a port is positive, that means energy is flowing into the network system. If the sign is negative, that means energy is flowing out of the network system. (Fig. 1). The total input and output energy of the network system can be calculated by integrating the product for each cases.

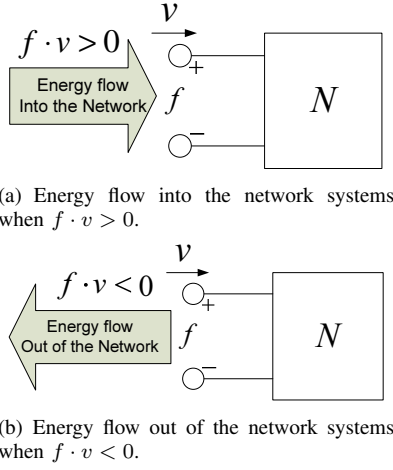

Fig. 1. Based on the sign of the product of force and velocity at a port, it is possible to differentiate whether energy is flowing into the network system or flowing out of the network system

$$E_{in}(k) = \begin{cases} E_{in}(k-1) + f(k)v(k) & \text{if } f(k)v(k) > 0 \\ E_{in}(k-1) & \text{if } f(k)v(k) \leq 0 \end{cases} \quad (2)$$

$$E_{out}(k) = \begin{cases} E_{out}(k-1) - f(k)v(k) & \text{if } f(k)v(k) < 0 \\ E_{out}(k-1) & \text{if } f(k)v(k) \geq 0 \end{cases} \quad (3)$$

With the above notation, the time-domain passivity condition for an one-port network [4] can be rewritten as follows:

$$E_{in}(k) \geq E_{out}(k) \quad (4)$$

For the bilateral controller two-port, input and output energy at each port can be calculated in a similar way as (2) and (3).

$$E_{in}^M(k) = \begin{cases} E_{in}^M(k-1) + f_m(k)v_m(k) & \text{if } f_m(k)v_m(k) > 0 \\ E_{in}^M(k-1) & \text{if } f_m(k)v_m(k) \leq 0 \end{cases} \quad (5)$$

$$E_{out}^M(k) = \begin{cases} E_{out}^M(k-1) - f_m(k)v_m(k) & \text{if } f_m(k)v_m(k) < 0 \\ E_{out}^M(k-1) & \text{if } f_m(k)v_m(k) \geq 0 \end{cases} \quad (6)$$

$$E_{in}^S(k) = \begin{cases} E_{in}^S(k-1) - f_s(k)v_s(k) & \text{if } f_s(k)v_s(k) < 0 \\ E_{in}^S(k-1) & \text{if } f_s(k)v_s(k) \geq 0 \end{cases} \quad (7)$$

$$E_{out}^S(k) = \begin{cases} E_{out}^S(k-1) + f_s(k)v_s(k) & \text{if } f_s(k)v_s(k) > 0 \\ E_{out}^S(k-1) & \text{if } f_s(k)v_s(k) \leq 0 \end{cases} \quad (8)$$

With the above notation, the time-domain passivity condition for two-port bilateral controller [10] can be rewritten as follows:

$$E_{in}^M(k) + E_{in}^S(k) \geq E_{out}^M(k) + E_{out}^S(k), \quad \forall k \geq 0 \quad (9)$$

In the previous approach, we adjusted  $E_{out}^M(k)$  and  $E_{out}^S(k)$  for satisfying the above single condition (9). However, if there is time-delay, the above condition (9) can not be checked in real-time anymore.

In teleoperation system with a bilateral control law, human operator gives energy to the bilateral controller with the master, and this energy is transmitted to the slave through the bilateral controller. When there is a reflected energy during the interaction between the slave and the environment, this energy is transmitted to the master through the bilateral controller. Based on this causality analysis, we can assume that the main source of the output energy at one port is the input energy at the other port (Fig. 2), and the output energy should be less than the input energy for satisfying the passivity condition. The following sufficient condition of (9) can be derived.

$$E_{in}^M(k) \geq E_{out}^S(k), \quad \forall k \geq 0 \quad (10)$$

$$E_{in}^S(k) \geq E_{out}^M(k), \quad \forall k \geq 0 \quad (11)$$

The output energy at the slave port should be less than the input energy at the master port, and the output energy at the master port should be less than the input energy at the slave port.

This sufficient condition is valid even for the case when there is time-varying communication delay. Assume that  $D^{MS}$  and  $D^{SM}$  are amount of communication delays from master to slave and slave to master, respectively. The above two conditions can be changed as follows:

$$E_{in}^M(k - D^{MS}) \geq E_{out}^S(k), \quad \forall k \geq 0 \quad (12)$$

$$E_{in}^S(k - D^{SM}) \geq E_{out}^M(k), \quad \forall k \geq 0 \quad (13)$$

The output energy at the slave port should be less than the input energy from the master port with delay, and the output energy at the master port should be less than the input energy from the slave port with delay.

Proof of the passivity with the derived sufficient condition is straightforward. If there is time-varying communication delay, the total energy flow at the two-port bilateral controller is like (14).

$$E_{obsv}(k) = E_{in}^M(k - D^{MS}) - E_{out}^S(k) + E_d^M + E_{in}^S(k - D^{SM}) - E_{out}^M(k) + E_d^S \quad (14)$$

Where  $E_d^M$  and  $E_d^S$  are always positive since these are the incremental values of each input energy during the delay.

$$E_d^M = E_{in}^M(k) - E_{in}^M(k - D^{MS}) \geq 0 \quad (15)$$

$$E_d^S = E_{in}^S(k) - E_{in}^S(k - D^{SM}) \geq 0 \quad (16)$$

Therefore, it is sufficient to satisfy (12) and (13) for guaranteeing the passivity of the teleoperator ( $E_{obsv}(k) \geq 0$ ).

Note that this proof is valid for the case with time-varying communication delay as well.

This sufficient condition can be satisfied by modifying each output energy  $E_{out}^S(k)$  and  $E_{out}^M(k)$ , which can be accessible in real-time by adding adaptive damping elements at each port (Fig. 3). Two series PCs are attached at each port of the bilateral controller. Two POs at each port are monitoring the input energy and output energy, separately. Input energy from the master ( $E_{in}^M$ ) is monitored by  $PO_{in}^M$  and transmitted to the  $PO_{out}^S$ , which monitor the output energy at the slave ( $E_{out}^S$ ), and adjusting the damping elements  $\alpha_2$  for bounding the output energy at the slave ( $E_{out}^S$ ). Input energy from the slave ( $E_{in}^S$ ) is monitored by  $PO_{in}^S$  and transmitted to the  $PO_{out}^M$ , which monitor the output energy at the master ( $E_{out}^M$ ), and adjusting the damping elements  $\alpha_1$  for bounding the output energy at the master ( $E_{out}^M$ ).

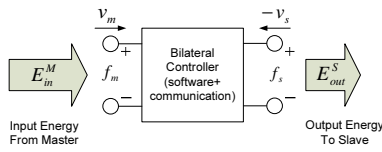

(a) Output energy to the slave should be less than the Input energy from the master for guaranteeing passivity.

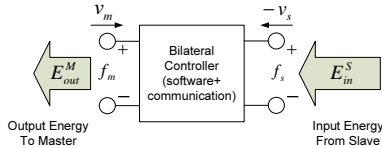

(b) Output energy to the master should be less than the Input energy from the slave for guaranteeing passivity.

Fig. 2. In teleoperation systems with bilateral control law, the main source of the output energy at one port is the input energy at the other port, and the output energy should be less than the input energy.

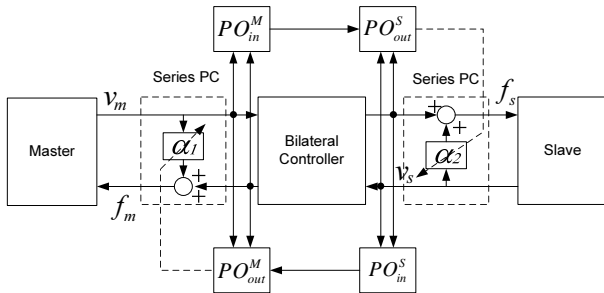

Fig. 3. Block diagram of a teleoperator with newly proposed PO/PC, considering time-delay. Two series PCs are attached at each port of bilateral controller.

### III. A PROBLEM CAUSED BY THE ACCUMULATED ENERGY DIFFERENCE

In this section, a problem in recent approach, which is about an unstable behavior due to the big energy difference

between input energy at one port and the output energy at the other port, is discussed.

First, experimental condition is introduced. Fig. 4 shows the experimental setup for the teleoperation with time delay. PHANToM was used for master and slave manipulator, and UDP connection was used for a data communication. A packet reflector at local site was introduced to make the experimental system experience a time-varying internet delay. The packet reflector has wireless internet connection to the both haptic server and haptic client.

Fig. 5 shows the amount of time-varying delay of the teleoperation system during an experiment. The communication had about 250 (msec) average time-delay for round trip, and varying between 175 (msec) and 330(msec). Since we have used UDP connection for data communication, some data packet might be lost during the communication. Fig. 6 shows the number of lost data packet during a communication experiment. Note that each packet was sent for every single millisecond.

Following position-position bilateral control architecture was used,

$$f_m(t) = K_p(X_s(t - T_D^{SM}) - X_m(t))$$

$$f_s(t) = K_p(X_m(t - T_D^{MS}) - X_s(t))$$

where  $K_p = 100(N/m)$  and  $T_D^{SM}$  and  $T_D^{MS}$  are time-varying communication delay from slave to master and master to slave, respectively.

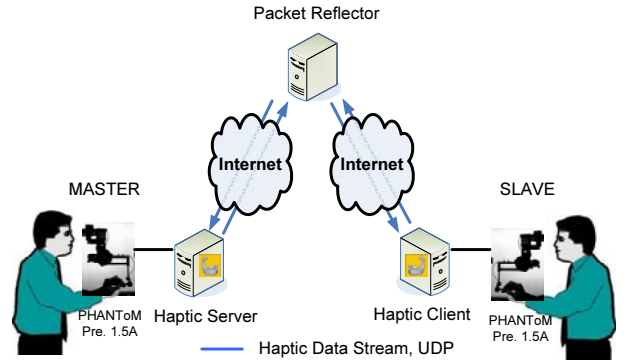

Fig. 4. Experimental setup for the teleoperation with time-delay

Operator maneuvered the master manipulator in free space with the recently proposed PC. Position and force response of the master and slave manipulator showed stable behavior until 2.0 (sec), but went to unstable after that. (Fig. 7(a), 7(b)). Even though the behavior was unstable and there is excessive energy output at the master port (Fig. 7(c)) and the slave port (Fig. 7(d)), the PC was not activated since the transmitted input energy from the master ( $E_{in}^M(t - T_d^{MS})$ ) and slave ( $E_{in}^S(t - T_d^{SM})$ ) were still greater than the output energy at the slave ( $E_{out}^S(t)$ ) and at the master ( $E_{out}^M(t)$ ), respectively. After certain period of stable operation, the input and output energy will be accumulated, and the difference will be getting bigger and bigger. Since the PC can

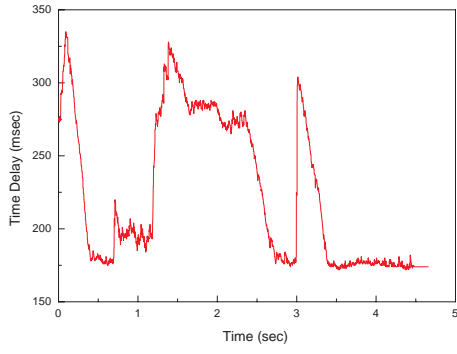

Fig. 5. Amount of time-varying delay of the teleoperation system during an experiment

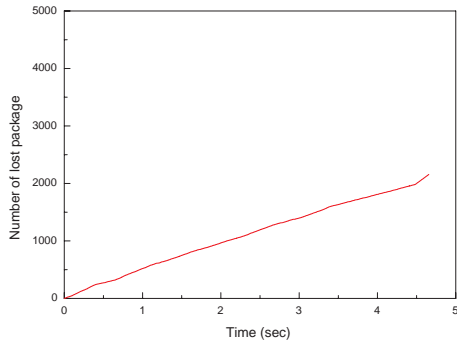

Fig. 6. Number of lost data packet during an experiment

not be activated until the output energy is greater than the input energy even though there is unstable oscillation and big amount of active energy output, this accumulated energy difference might be a problem for a long period of operation.

#### IV. ENERGY RESETTING SCHEME

In this Section, a simple resetting scheme is proposed for removing the accumulated energy difference. If there is no active energy output for certain period of time at a port, we reset the accumulated energy output at the port as the transmitted input energy from the other port.

$$\begin{aligned} & \text{IF } f_m(k)v_m(k) \geq 0, \quad \text{for } N - M < k \leq N \\ & \text{THEN } E_{out}^M(N) = E_{in}^S(N - T_d^{SM}) \end{aligned} \quad (17)$$

$$\begin{aligned} & \text{IF } f_s(k)v_s(k) \geq 0, \quad \text{for } P - M < k \leq P \\ & \text{THEN } E_{out}^S(P) = E_{in}^M(P - T_d^{MS}) \end{aligned} \quad (18)$$

where  $M$  is the number of sampling time which the user need to design for resetting. If the output energy stay above zero, which means there is no active energy flow, during  $M$  sampling time, we reset the accumulated output energy to the delayed input energy.

Resetting the accumulated output energy is equal to add the accumulated energy difference to (14) as follows:

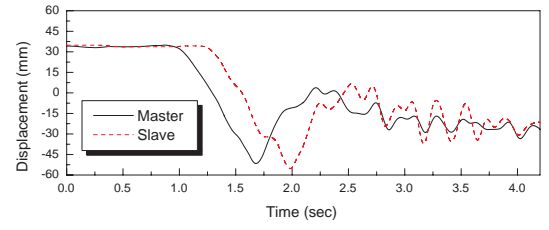

(a) Position response of the master and slave

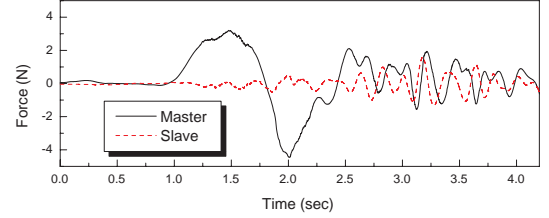

(b) Control force of the master and slave

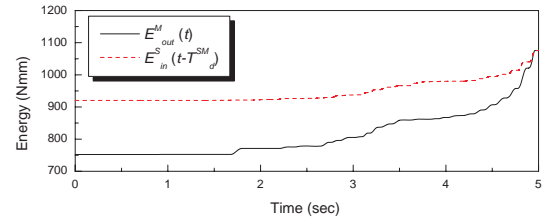

(c) Output energy to the master and input energy from the slave with delay.

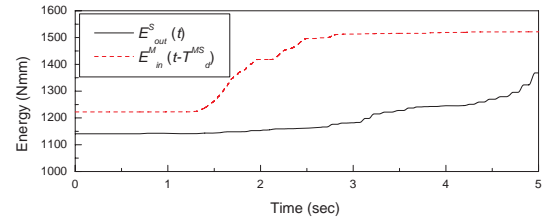

(d) Output energy to the slave and input energy from the slave with delay.

Fig. 7. Free motion with time-varying communication delay and packet loss with recently proposed PC.

$$\begin{aligned} E_{obsv}(k) &= E_{in}^M(k - D^{MS}) - E_{out}^S(k) + E_d^M \\ &\quad - E_{in}^M(P - D^{MS}) + E_{out}^S(P) \\ &\quad + E_{in}^S(k - D^{SM}) - E_{out}^M(k) + E_d^S \\ &\quad - E_{in}^S(N - D^{SM}) + E_{out}^M(N). \end{aligned} \quad (19)$$

Therefore the sufficient condition (12) and (13) can be changed as follows:

$$\begin{aligned} E_{in}^M(k - D^{MS}) - E_{in}^M(P - D^{MS}) + E_{out}^S(P) \\ \geq E_{out}^S(k), \quad \forall k \geq 0 \end{aligned} \quad (20)$$

$$\begin{aligned} E_{in}^S(k - D^{SM}) - E_{in}^S(N - D^{SM}) + E_{out}^M(N) \\ \geq E_{out}^M(k), \quad \forall k \geq 0 \end{aligned} \quad (21)$$

where those added terms are negative. As a result, the resetting scheme allow the less active output energy, which

makes the controller more conservatively guarantee the system passivity.

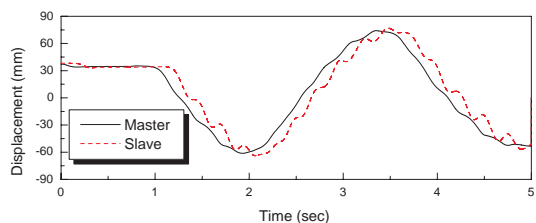

(a) Position response of the master and slave

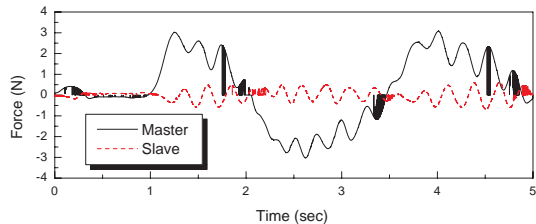

(b) Control force of the master and slave

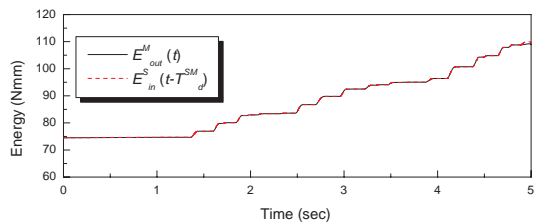

(c) Output energy to the master and input energy from the slave with delay.

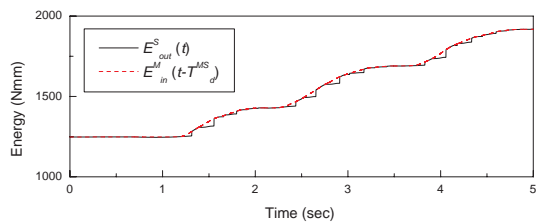

(d) Output energy to the slave and input energy from the slave with delay.

Fig. 8. Free motion with time-varying communication delay and packet loss with resetting.

Same experiment as in Fig. 7 has been performed with the proposed resetting scheme. The accumulated energy difference was removed by resetting the output energy at each port based on (17) and (18). Thanks to the resetting scheme, position response of the master and slave manipulator showed stable behavior (Fig. 8) without worrying about accumulated energy difference.

We made a hard contact with about the same communication time-delay and with the proposed resetting scheme. The contact started about 2 (sec) and ended about 3.7 (sec). Position response of the master and slave manipulator was stable (Fig. 9(a)). However noisy behavior, which is worse than the most recent approach, is found during the contact (Fig. 9(b)). As we have already mentioned that the resetting scheme made the controller more conservative, this noisy

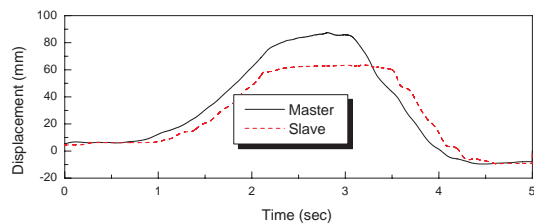

(a) Position response of the master and slave

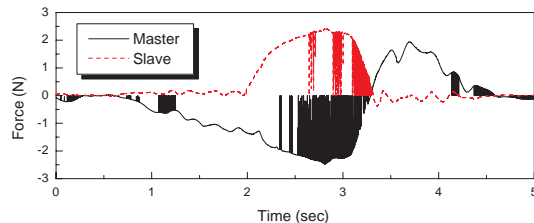

(b) Control force of the master and slave

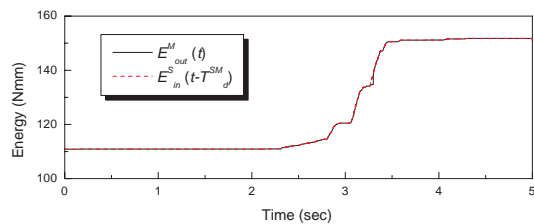

(c) Output energy to the master and input energy from the slave with delay.

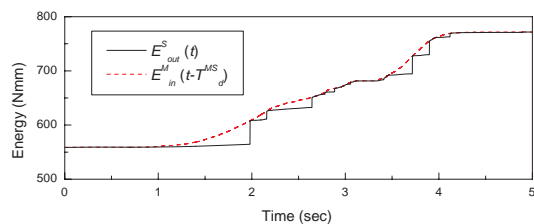

(d) Output energy to the slave and input energy from the slave with delay.

Fig. 9. Hard contact with time-varying communication delay and packet loss with resetting.

behavior of the PC partly comes from the resetting scheme since the resetting scheme allows less active energy output.

## V. CONCLUSIONS AND FUTURE WORKS

This paper improved the recently modified two-port time-domain passivity approach by solving the accumulated energy difference problem. Resetting scheme, which modify the output energy value, was introduced and solved the potentially unstable problem. Even though the proposed resetting scheme made the PO/PC more conservative, it can guarantee the system stability without worrying about the accumulated energy difference.

## REFERENCES

- [1] R. J. Anderson and M. W. Spong, "Bilateral Control of Teleoperators with Time Delay," *IEEE Trans. on Automatic Control*, Vol. 34, No. 5, pp. 494-501, 1989.

- [2] R. J. Anderson and M. W. Spong, "Asymptotic Stability for Force Reflecting Teleoperators with Time Delay," *Int. Journal of Robotics Research*, Vol. 11, No. 2, pp. 135-149, 1992.
- [3] K. Goldberg et al., "The Mercury Project: A Feasibility Study for Internet Robots," *IEEE Robotics and Automation Magazine (Special Issue on "Robots on the Web")*, Vol. 7, No. 1, pp. 35-40, 2000.
- [4] B. Hannaford and J. H. Ryu, "Time Domain Passivity Control of Haptic Interfaces," *IEEE Trans. on Robotics and Automation*, vol. 18, no. 1, pp. 1-10, 2002.
- [5] K. Kosuge et al., "Bilateral Feedback Control of Telemanipulators via Computer Network," *IEEE/RSJ IROS'96*, pp. 1380-1385, 1996.
- [6] G. M. H. Leung et al., "Bilateral Controller for Teleoperators with Time Delay via  $\mu$ -Synthesis," *IEEE Trans. on Robotics and Automation*, Vol. 11, No. 1, pp. 105-116, 1995.
- [7] G. Niemeyer and J. J. E. Slotine, "Stable Adaptive Teleoperation," *IEEE J. of Oceanic Engineering*, Vol. 16, No. 1, pp. 152-162, 1991.
- [8] G. Niemeyer and J. J. E. Slotine, "Toward Force-Reflecting Teleoperation Over the Internet," *IEEE ICRA'98*, pp. 1909-1915, 1998.
- [9] R. Oboe and P. Fiorini, "A Design and Control Environment for Internet-Based Telerobotics," *International Journal of Robotics Research*, Vol. 17, No. 4, pp. 433-449, 1998.
- [10] J. H. Ryu, D. S. Kwon and B. Hannaford, "Stable Teleoperation with Time Domain Passivity Control," *IEEE Trans. on Robotics and Automation*, vol. 20, no. 2, pp. 365-373, 2004.
- [11] J. H. Ryu, Y. S. Kim and B. Hannaford, "Sampled and Continuous Time Passivity and Stability of Virtual Environments," *IEEE Trans. on Robotics*, vol. 20, no. 4, pp. 772-776, 2004.
- [12] J. H. Ryu, B. Hannaford, C. Preusche, and G. Hirzinger "Time Domain Passivity Control with Reference Energy Behavior," *IEEE Trans. on Control Systems Technology*, Vol. 13, No. 5, pp. 737-742, 2005.
- [13] J. H. Ryu, D. S. Kwon and B. Hannaford, "Stability Guaranteed Control: Time Domain Passivity Approach," *IEEE Trans. on Control Systems Technology*, Vol. 12, No. 6, pp. 860-868, 2004.
- [14] J. H. Ryu, C. Preusche, "Stable Bilateral Control of Teleoperators Under Time-varying Communication Delay: Time Domain Passivity Approach," *will be appear in IEEE ICRA'07*.
- [15] A. Santo et al. "Network-Based Toward Force-Reflecting Teleoperation," *IEEE ICRA'2000*, pp. 3126-3131, 2000.
- [16] T. B. Sheridan, "Space Teleoperation Through Time Delay: Review and Prognosis," *IEEE Trans. on Robotics and Automation*, Vol. 9, No. 5, pp. 592-606, 1993.
- [17] J. Vertut and P. Coiffet, *Robot Technology, Volume 3A: Teleoperations and Robotics: Evolution and Development.*, Prentice Hall, Englewood Cliffs, NJ; 1986.
- [18] A. J. van der Schaft, "L2-Gain and Passivity Techniques in Nonlinear Control," Springer, Communications and Control Engineering Series, 2000.
- [19] J. C. Willems, "Dissipative Dynamical Systems, Part I: General Theory," *Arch. Rat. Mech. An.*, vol. 45, pp. 321-351, 1972.
- [20] Y. Yokokohji et al., "Bilateral Teleoperation under Time-Varying Communication Delay," *IEEE/RSJ IROS'99*, pp. 1854-1859, 1999.
- [21] Y. Yokokohji and T. Yoshikawa, "Bilateral Control of Master-slave Manipulators for Ideal Kinesthetic Coupling-Formulation and Experiment," *IEEE Trans. on Robotics and Automation*, Vol. 10, No. 5, pp. 605-620, 1994.