

## ACKNOWLEDGMENT

The authors express their thanks to Mr. T. Matsuda, a graduate student of University of Tsukuba, for his assistance.

## REFERENCES

- [1] H. Arai, K. Tanie, and N. Shiroma, "Nonholonomic control of a three-DOF planar underactuated manipulator," *IEEE Trans. Robot. Automat.*, vol. 14, pp. 681–695, Oct. 1998.
- [2] K. S. Hong, "An open-loop control for underactuated manipulators using oscillatory inputs: Steering capability of an unactuated joint," *IEEE Trans. Contr. Syst. Technol.*, vol. 10, pp. 469–480, May 2002.
- [3] H. Arai and S. Tachi, "Position control of a manipulator with passive joints using dynamic coupling," *IEEE Trans. Robot. Automat.*, vol. 7, pp. 528–534, Aug. 1991.
- [4] K. H. Yu, Y. Shito, and H. Inooka, "Position control of an underactuated manipulator using joint friction," *Int. J. Non-Linear Mech.*, vol. 33, pp. 607–614, 1998.
- [5] Y. Nakamura, T. Suzuki, and M. Koinuma, "Nonlinear behavior and control of a nonholonomic free-joint manipulator," *IEEE Trans. Robot. Automat.*, vol. 13, pp. 853–862, Dec. 1997.
- [6] I. Fantoni, L. Lozano, and M. W. Spong, "Energy-based control of the pendubot," *IEEE Trans. Automat. Contr.*, vol. 45, pp. 725–729, Apr. 2000.
- [7] P. L. Kapitza, "Dynamical stability of a pendulum when its point of suspension vibrates, and pendulum with a vibrating suspension," in *Collected Papers of P. L. Kapitza*, D. T. Haar, Ed. London, U.K.: Pergamon, 1965, vol. 2, pp. 714–737.
- [8] A. Stephenson, "On a new type of dynamical stability," *Mem. Proc. Manch. Lit. Phil. Sci.*, vol. 52, pp. 1–10, 1908.
- [9] R. E. Bellman, J. Bentsman, and S. M. Meerkov, "Vibrational control of a class of nonlinear systems: Vibrational stabilization," *IEEE Trans. Automat. Contr.*, vol. AC-31, pp. 710–716, Aug. 1986.
- [10] S. P. Weibel and J. Bailliwul, "Open-loop oscillatory stabilization of an  $n$ -pendulum," *Int. J. Control*, vol. 71, pp. 931–957, 1998.
- [11] T. Suzuki and Y. Nakayama, "Anti-gravity control of free-joint manipulators by vibrational input," in *Proc. Int. Conf. Robotics and Automation*, vol. 2, May 2002, pp. 1315–1320.
- [12] H. Yabuno, M. Miura, and N. Aoshima, "Bifurcation in an inverted pendulum with tilted high-frequency excitation," *J. Sound, Vibration*, to be published.
- [13] J. Guckenheimer and P. Holmes, *Nonlinear Oscillations, Dynamical Systems, and Bifurcations of Vector Fields*. New York: Springer-Verlag, 1983, pp. 149–150.
- [14] M. Golubitsky and D. G. Schaeffer, *Singularities and Groups in Bifurcation Theory*. New York: Springer-Verlag, 1985, pp. 2–10.
- [15] L. Meirovitch, *Elements of Vibration Analysis*. New York: McGraw-Hill, 1986, pp. 30–31.
- [16] S. A. Nayfeh and A. H. Nayfeh, "The response of nonlinear systems to modulated high-frequency input," *Nonlinear Dynam.*, vol. 7, pp. 301–315, 1995.
- [17] A. H. Nayfeh, *Introduction to Perturbation Techniques*. New York: Wiley, 1981, pp. 122–127.
- [18] J. M. T. Thompson and G. W. Hunt, *Elastic Instability Phenomena*. Chichester, U. K.: Wiley, 1984, pp. 43–47.
- [19] H. Yabuno, Y. Kurata, and N. Aoshima, "Effect of Coulomb damping on buckling of a two-rods system," *Nonlinear Dynam.*, vol. 15, pp. 207–224, 1998.
- [20] T. Poston and I. Stewart, *Catastrophe Theory and its Applications*. London, U.K.: Pitman, 1978, pp. 78–83.

## Stable Teleoperation With Time-Domain Passivity Control

Jee-Hwan Ryu, Dong-Soo Kwon, and Blake Hannaford

**Abstract**—A new bilateral control scheme is proposed to ensure stable teleoperation under a wide variety of environments and operating speeds. System stability is analyzed in terms of the time-domain definition of passivity. A previously proposed energy-based method is extended to a 2-port network, and the issues in implementing the "passivity observer" and "passivity controller" to teleoperation systems are studied. The method is tested with our two-degrees-of-freedom master/slave teleoperation system. Stable teleoperation is achieved under conditions such as hard wall contact (stiffness > 150 kN/m) and hard surface following.

**Index Terms**—Passivity controller, passivity observer, teleoperation system, time-domain passivity.

## I. INTRODUCTION

The goal of teleoperation system control is to achieve transparency while maintaining stability (i.e., such that the system does not exhibit vibration or divergent behavior), under any operating conditions and for any environments. To this end, several bilateral control architectures have thus far been developed [7], [11], [13], [22], [23], [27].

In designing the bilateral controller, a classic engineering tradeoff between transparency and stability has been an important issue, since transparency must often be reduced in order to guarantee stable operation in the wide range of environment impedances (for example, in terms of stiffness of "free space" and "hard contact"). This has necessitated investigating methods to increase transparency without introducing instability. Several previous studies have sought out theoretical design methods for control parameters, based on linear circuit theory [1], [12] or linear robust control theory [4], [18], [26].

However, the teleoperation systems of our interest are nonlinear, and the dynamic properties of a human operator are always involved. These factors make it difficult to analyze teleoperation systems in terms of known parameters and linear control theory. To cope with the nonlinearity and uncertain parameters of the teleoperation system, several researchers have used nonlinear control laws, such as adaptive control, to design the bilateral controller [10], [17], [21], [29]. However, this approach requires, at the very least, system dynamic equations, and the system uncertainty should be captured with a few unknown parameters. Generally, it is very difficult to obtain an exact dynamic model of the teleoperation system. Furthermore, the dynamic structure of a teleoperation system is too complicated to capture with just a few parameters. Thus, it becomes very complicated to apply this model-based approach when the teleoperation system has high degrees of freedom (DOFs).

One promising approach is the use of the idea of passivity to guarantee stable operation without exact knowledge of model information. Anderson and Spong [3] and Neimeyer and Slotine [20] have used

Manuscript received November 21, 2002; revised August 5, 2003. This paper was recommended for publication by Associate Editor P. Dupont and Editor A. De Luca upon evaluation of the reviewers' comments. This work was supported in part by a grant from Ford Motor Company, and in part by the Postdoctoral Fellowship Program of the Korea Science and Engineering Foundation (KOSEF).

J.-H. Ryu is with the Department of Electrical Engineering and Computer Science, Korea Advanced Institute of Science and Technology, Taejeon 305-701, Korea (e-mail: jhryu@rit.kaist.ac.kr).

D.-S. Kwon is with the Department of Mechanical Engineering, Korea Advanced Institute of Science and Technology, Taejeon 305-701, Korea (e-mail: kwonds@kaist.ac.kr).

B. Hannaford is with the Department of Electrical Engineering, University of Washington, Seattle, WA 98195-2500 USA (e-mail: blake@u.washington.edu).  
Digital Object Identifier 10.1109/TRA.2004.824689

passivity concepts for stable teleoperation when a time delay exists. Yokokohji *et al.* [28] have introduced an energy-monitoring method to satisfy passivity under time-varying communication delay. Lozano *et al.* [19] also presented an idea to solve the time-varying delay problem based on passivity. Lee and Li [15], [16] proposed a method to make the teleoperation system passive using fictitious energy storage. Colgate and Schenkel [5] have used passivity to derive fixed-parameter virtual coupling (i.e., haptic interface controllers). Anderson [2] has implemented the passive module idea to teleoperation systems. However, the use of the passivity for designing teleoperation systems has resulted in an overly conservative controller, since they have analyzed system passivity in the frequency domain, which could not avoid fixed damping design. Thus, in many cases, performance can be poor, since a fixed damping value is derived for guaranteeing passivity under all operating conditions. Recently, Hannaford and Ryu [8] have proposed a new energy-based method for stable haptic interaction, and proved and experimentally tested stability with minimal performance loss for 1-port haptic interaction.

This paper extends the time-domain passivity control approach to apply to teleoperation systems. The design method is extended to the 2-port network, and implementation issues are investigated.

## II. NETWORK MODEL AND STABILITY CONDITION

Fig. 1 shows a network model of a teleoperation system, where  $v_h$  and  $v_e$  denote the velocities at the interacting points of the human/master and environment/slave, respectively, and  $f_h$  and  $f_e$  represent the force that the operator applies to the master manipulator and the slave manipulator applies to the environment, respectively.

To investigate the stability of the teleoperation system, we analyze the network model based on the idea of passivity. If individual blocks of the network model are passive, the overall system is passive, and it is sufficient to make the system stable [6]. If we assume that the operator and the environment are passive, the teleoperator 2-port must be passive to meet the sufficient condition for stability [3], [27]. Generally, the environments are passive, and based on Hogan's experiment [9], we can assume that the human operator can be modeled as a passive network. Thus, we only need to make the teleoperator 2-port passive to satisfy the stability of the teleoperation system.

We then use the following widely known definitions of passivity for a multiport network.

**Definition 1:** An  $M$ -port network with initial energy storage  $E(0)$ , is passive, if and only if

$$\int_0^t (f_1(\tau) v_1(\tau) + \dots + f_M(\tau) v_M(\tau)) d\tau + E(0) \geq 0, \quad \forall t \geq 0 \quad (1)$$

for admissible forces  $(f_1, \dots, f_M)$  and velocities  $(v_1, \dots, v_M)$ . The sign convention for all forces and velocities is defined to make their product positive when power enters the system port [Fig. 2(b)]. The system is also assumed to have initial stored energy at  $t = 0$  of  $E(0)$ . Equation (1) states that the energy supplied to a passive network must be greater than negative  $E(0)$  for all time [24], [25].

## III. REVIEW OF THE TIME-DOMAIN PASSIVITY CONTROL

This section reviews the "passivity observer" (PO) and "passivity controller" (PC) (Hannaford and Ryu 2001), which have been applied to a 1-port network for application to haptic interfaces. For a 1-port network [Fig. 2(a)] with zero initial energy storage, if we can measure the conjugate variables ( $f$  and  $v$ ), which define power flow into a system, and the sampling rate is substantially faster than the dynamics of the system so that the change in force and velocity with each sample is small, we can easily instrument one or more blocks in the system with

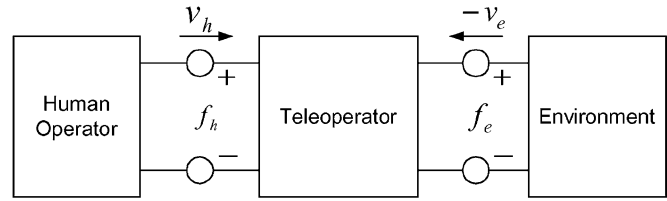

Fig. 1. 2-port network representation of teleoperation systems. System blocks are (left to right) human operator, teleoperator, and environment.

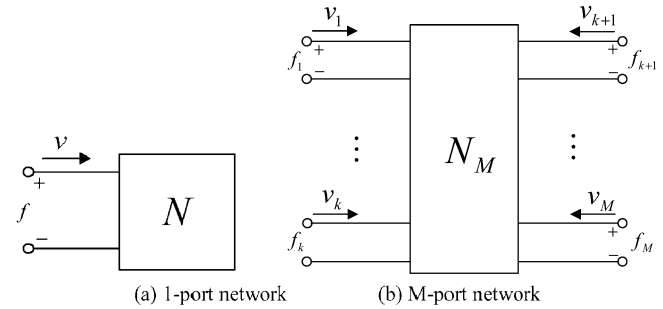

Fig. 2. (a) 1-port network. (b)  $M$ -port network. Representing components.

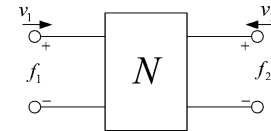

Fig. 3. 2-port networks representing components.

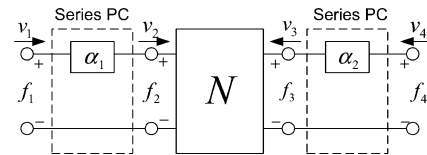

Fig. 4. Series configurations of PC for 2-port networks.  $\alpha_1$  and  $\alpha_2$  are adjustable damping elements at each port. Choice of configuration depends on input/output causality of model underlying each port.

the following PO to measure energy flow into the 1-port network in real time

$$E_{\text{obsv}}(n) = \Delta T \sum_{k=0}^n f(k) v(k) \quad (2)$$

where  $\Delta T$  is the sampling period. If  $E_{\text{obsv}}(n) \geq 0$  for every  $n$ , this means the system stores and/or dissipates energy. If there is an instance where  $E_{\text{obsv}}(n) < 0$ , this means the system generates energy and the amount of generated energy is  $-E_{\text{obsv}}(n)$ . Note that it is generally possible to consider that the initial energy of a network system is zero, since we start the operation with no initial deflection and errors for haptic and teleoperation systems.

Consider a 1-port system which may be active. Depending on operating conditions and the specifics of the 1-port element's dynamics, the PO may or may not be negative at a particular time. However, if it is negative at any time, we know that the 1-port may then be contributing to instability. Moreover, we know the amount of generated energy and we can design a time-varying element to dissipate only the required amount of energy. We call this element a PC [8].

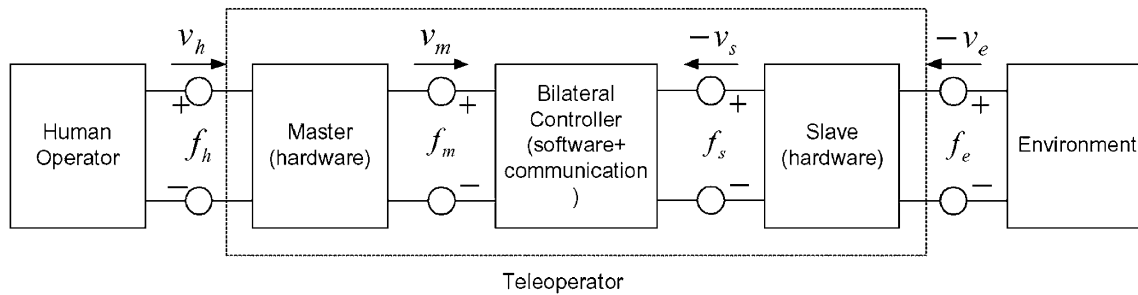

Fig. 5. Block diagram of a complete teleoperation system. System blocks are (left to right) human operator, hardware part of master, bilateral controller including control software and communication channel, hardware of slave, and environment.

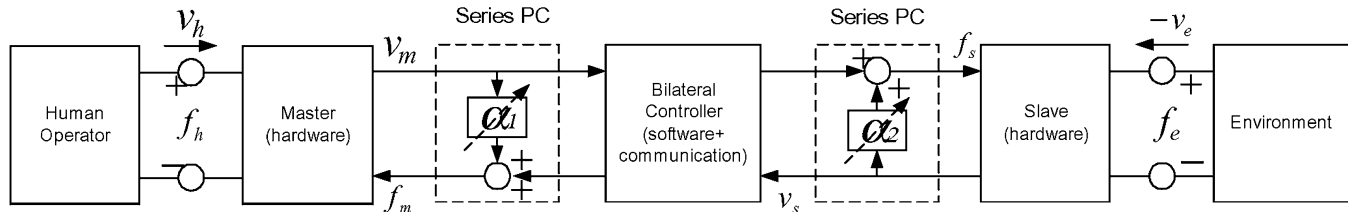

Fig. 6. Block diagram of a complete teleoperation system with PC. Two series PCs are attached at each port of the bilateral controller.

#### IV. TIME-DOMAIN PASSIVITY CONTROL FOR 2-PORT NETWORKS

This section extends the PO and PC to a 2-port network for guaranteeing the stability of a teleoperation system by making the teleoperator 2-port passive. Similar to the 1-port case, the PO can be designed for a 2-port network (Fig. 3)

$$E_{\text{obsv}}(n) = \Delta T \sum_{k=0}^n (f_1(k) v_1(k) + f_2(k) v_2(k)) = \Delta T \cdot W(n). \quad (3)$$

For designing PC, unlike a 1-port network, two points should be considered:

- 1) add the PC at each port;
- 2) activate the PC at active port.

If only one PC is placed at either port (let us assume first port), there might be some instance  $E_{\text{obsv}}(n) < 0$ , even though  $v_1 = 0$  (or  $f_1 = 0$ ). In that case, the generated energy at the other port cannot be dissipated, since the only PC at the first port cannot be activated with the zero-input signal. Consequently, another PC should be placed at the other port to dissipate the active energy output.

In addition, we have to consider how to activate the PC at each port to make the 2-port network passive. Mathematically, there are two ways to make the 2-port network passive (the total sum of energy is greater than zero):

- make the produced energy less than the absorbed energy: activate the PC at the active port to cut the active energy output;
- make the absorbed energy greater than the produced energy: activating the PC at the passive port to absorb more energy to satisfy this mathematical condition.

However, increasing the absorbed energy to make the network passive is not reasonable in a physical sense. For example, if the PC is placed between the 2-port network and an infinite energy source (such as effort or flow source), and the PC increases the absorbed energy to make the 2-port network passive, the total system energy may not be bounded. Thus, it is more feasible to make the produced energy less than the absorbed energy by activating the PC only at the active port. Note that it is possible to know which port is active or passive by monitoring the conjugate signal pair of each port in real time, such as

$$\text{status of a port} = \begin{cases} \text{Active,} & \text{if } f \cdot v < 0 \\ \text{Passive,} & \text{if } f \cdot v \geq 0. \end{cases}$$

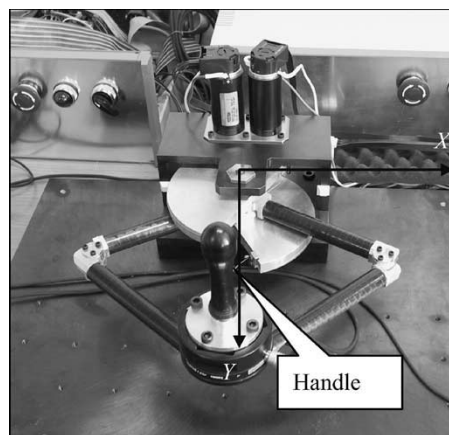

(a) Master manipulator

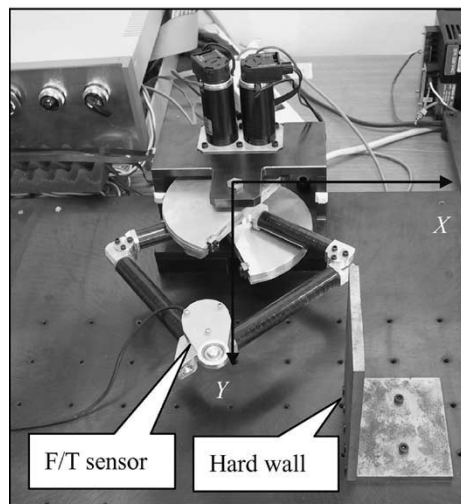

(b) Slave manipulator

Fig. 7. (a) Two-DOF master manipulator. (b) Two-DOF slave manipulator for teleoperation.

Based on the above, for a 2-port network with impedance causality at each port, we can design two series PCs (Fig. 4) in real time, as follows:

- 1)  $v_1(n) = v_2(n)$  and  $v_3(n) = v_4(n)$  are inputs;
- 2)  $f_2(n)$  and  $f_3(n)$  are the outputs of the system;
- 3)

$$W(n) = \sum_{k=0}^{n-1} (f_1(k)v_1(k) + f_4(k)v_4(k)) + f_2(n)v_2(n) + f_3(n)v_3(n)$$

is the PO;

- 4) two series PCs can be designed for several cases, as shown in the table at the bottom of the page;
- 5)  $f_1(n) = f_2(n) + \alpha_1(n)v_2(n) \Rightarrow$  output;
- 6)  $f_4(n) = f_3(n) + \alpha_2(n)v_3(n) \Rightarrow$  output;

where each case is as follows.

- Case 1:  $W(n) \geq 0$ . In this case, energy does not flow out. There is no need to activate any PC.
- Case 2:  $W(n) < 0, f_2(n)v_2(n) < 0, f_3(n)v_3(n) \geq 0$ . In this case, energy flows out from the left port. We need to activate only the left PC.
- Case 3:  $W(n) < 0, f_2(n)v_2(n) \geq 0, f_3(n)v_3(n) < 0$ . In this case, energy flows out from the right port. We need to activate only the right PC.
- Case 4:  $W(n) < 0, f_2(n)v_2(n) < 0, f_3(n)v_3(n) < 0$ . In this case, energy flows out from both ports. To correct this active behavior, the PC must supply dissipation equal to  $-W(n)$ . For an impedance causality, we must allocate this damping among the 2-ports such that  $\alpha_1(n)v_1(n)^2 + \alpha_2(n)v_2(n)^2 = -W(n)$ .

We will give an example in which we prefer to allocate damping to the left port and the remainder to the right, but many other strategies are possible. The first case is when the produced energy from the right port is greater than the previously dissipated energy, as shown next.

- Case 4.1:  $W(n-1) + f_3(n)v_3(n) < 0$ . In this case, we only have to dissipate the net generation energy of the right port as the fifth column in Case 4. The second case is when the produced energy from the right port is less than the previously dissipated energy.
- Case 4.2:  $W(n-1) + f_3(n)v_3(n) > 0$ . In this case, we do not need to activate the right port PC, and also reduce the conservatism of the left port PC as the sixth column in Case 4.

We can demonstrate that the system computed by Case 4 is passive in the following:

$$\begin{aligned} & \sum_{k=0}^n (f_1(k)v_1(k) + f_4(k)v_4(k)) \\ &= \sum_{k=0}^n f_2(k)v_2(k) + \sum_{k=0}^n f_3(k)v_3(k) \\ & \quad + \sum_{k=0}^n \alpha_1(k)v_2(k)^2 + \sum_{k=0}^n \alpha_2(k)v_3(k)^2 \end{aligned} \quad (4)$$

$$\begin{aligned} &= \sum_{k=0}^n f_2(k)v_2(k) + \sum_{k=0}^n f_3(k)v_3(k) + \sum_{k=0}^{n-1} \alpha_1(k)v_2(k)^2 \\ & \quad + \sum_{k=0}^{n-1} \alpha_2(k)v_3(k)^2 + \alpha_1(n)v_2(n)^2 + \alpha_2(n)v_3(n)^2 \\ &= W(n) + \alpha_1(n)v_2(n)^2 + \alpha_2(n)v_3(n)^2. \end{aligned} \quad (5)$$

Using Case 4, we can make the 2-port network passive under all conditions,  $\sum_{k=0}^n (f_1(k)v_1(k) + f_4(k)v_4(k)) \geq 0 \quad \forall n$ .

The case of admittance causality can be similarly derived with a parallel PC. When the PC design is extended for a multiport network, the cases are increased by  $2^N$ , where  $N$  is the number of ports. However, the basic design rule is not changed. The PC is attached at each port of the network, and the PC is activated when the network becomes active and energy is produced at this port. One thing to determine is how to distribute the damping, considering the previous energy dissipation, when energy flows out through more than one port. One of the possibilities is distributing the damping proportional to velocity (or force) at the port. We are currently studying the optimal damping distribution. Note that the damping at the active port, at most, reduces forces to zero (not negative).

## V. IMPLEMENTATION ISSUES OF TELEOPERATION SYSTEMS

This section addresses how to implement the developed 2-port PO/PC to teleoperation systems. There are two issues to be considered for implementing PO/PC.

### A. Location of the PO/PC

First, to determine the place to locate the PO/PC, it is necessary to check the real-time availability of the conjugate signal pair at each port. In addition to the real-time availability, the conjugate output (which depends on causality) should be changed to a desired value in real time for implementing the PC. Since our goal is making the teleoperator 2-port passive, it seems reasonable to place the PO/PC at the teleoperator 2-port. If the forces ( $f_h, f_e$ ) and the velocities ( $v_h, v_e$ ) can be measured in real time at both ports, it is usually possible to construct the PO [(3)]. However, these signals cannot be modified in real time, since these are responses of a physical interaction between human/environment and the teleoperator.

In this case, we can exclude some passive blocks while constructing an accessible conjugate pair without ruining the overall passivity. Physically, energy is transmitted to a physical system through the place where an actuator is placed, and the physical energy which is transmitted through the actuator can be calculated with the conjugate pair which defines power flow from the actuator, such as force output from the actuator and the velocity at the actuating position. Based on this fact, we can divide the teleoperator into three parts: the mechanical part of the master manipulator; master/slave controller and communication channel; and the mechanical part of the slave manipulator. Fig. 5 shows a complete network model of a teleoperation system which is representing actual physical energy flows. The bilateral controller exchanges energy with the mechanical parts of the master/slave manipulator, and this energy flow can be measured with the conjugate pairs ( $f_m, v_m$  and

Case	1	2	3	4.1	4.2
$\alpha_1(n)$	0	$\frac{-W(n)}{v_2(n)^2}$	0	$\frac{-f_2(n)v_2(n)}{v_2(n)^2}$	$\frac{-W(n)}{v_2(n)^2}$
$\alpha_2(n)$	0	0	$\frac{-W(n)}{v_3(n)^2}$	$\frac{-(W(n-1) + f_3(n)v_3(n))}{v_3(n)^2}$	0

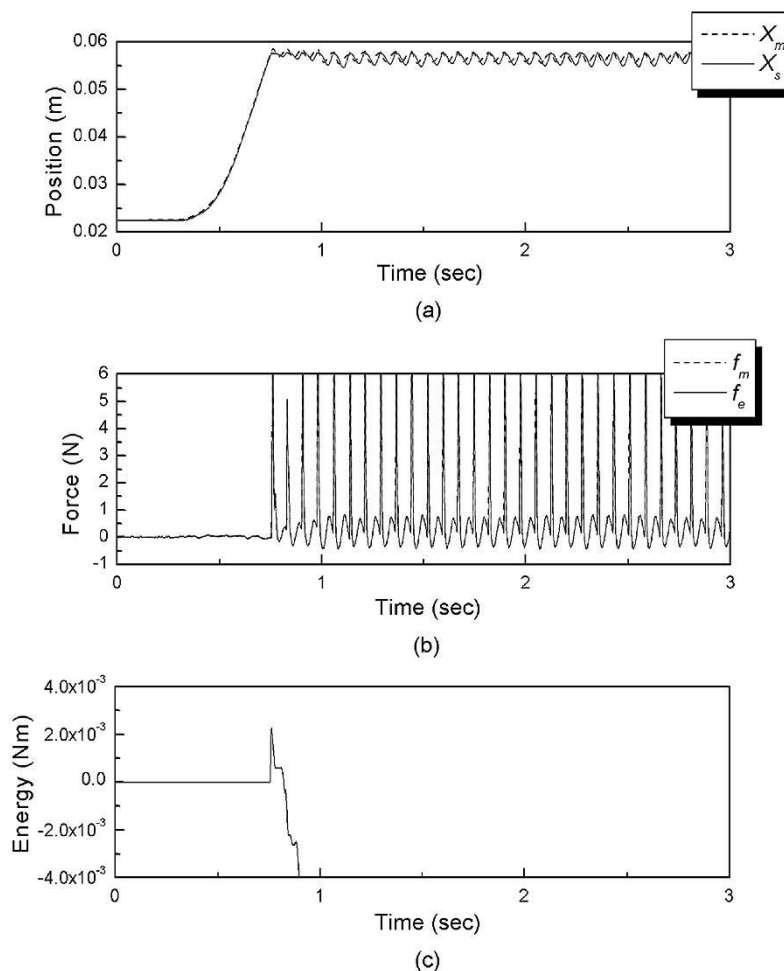

Fig. 8. Experimental results: Hard contact with high velocity (about 120 mm/s). PC is inactive (bottom trace) and system exhibits sustained contact oscillations.

$f_s, v_s$ ).  $f_m$  and  $f_s$  are actuator driving forces of the mechanical part of the master and slave manipulators, and  $v_m$  and  $v_s$  are velocities at the actuating place. The mechanical parts of the master and slave manipulator can be excluded, since these do not make the teleoperator active due to their inherent dissipative elements. Thus, it is sufficient to make the bilateral controller passive for making the teleoperator passive. To make the bilateral controller passive, the PO is designed as

$$E_{\text{obsv}}(n) = \Delta T \sum_{k=0}^n (f_m(k) v_m(k) + f_s(k) v_s(k)) = \Delta T \cdot W(n)$$

and placed at the bilateral controller 2-port. As we intended, the conjugate pairs ( $f_m, v_m$  and  $f_s, v_s$ ) can be accessible in real time. Note that the PC is not included in the current PO iteration ( $n$ ), since the PC is calculated based on the current PO value (refer to Case 3 of the PC algorithm).

### B. Type of the PC

To determine the type of the passivity controller, it is required to determine the causality of each port of the bilateral controller. Usually motors are used for the actuator of the master and the slave manipulators, and motors have admittance causality and the bilateral controller has impedance causality at both ports. The inputs of the bilateral controller could be the velocity of the master ( $v_m$ ) and the slave ( $v_s$ ), and the outputs of the bilateral controller are control inputs of the master

( $f_m$ ) and the slave ( $f_s$ ) at each port. Thus, the series type is the suitable configuration of the PC to absorb the energy output from the bilateral controller. Fig. 6 shows the teleoperation system with the PC. Note that the series PC appears to be connected in parallel, but this is an artifact of switching to block-diagram notation for the connections between the master/slave, PC, and the bilateral controller.

## VI. EXPERIMENTAL RESULTS

Based on the above studies, the PO and PC are implemented in a teleoperation system that has a two-DOF master [Fig. 7(a)] and a two-DOF slave manipulator [Fig. 7(b)]. Master and slave manipulators have a five-bar mechanism, and can display 2 Nm for each joint axis. Each joint axis of the master and slave senses position in  $1.6716 \times 10^{-4}$  rad and  $1.6519 \times 10^{-4}$  rad increments, respectively. As a high-stiffness environment, a steel wall is placed parallel to the  $Y$  axis. This system is entirely synchronous at 1000 Hz.

To experimentally study the PO/PC, we used a traditional bilateral control system (position-force), in which a position command is sent from master to slave and a force command is returned from slave to master. The slave robot has a proportional-derivative (PD) control law for end-effector position. In such an architecture, transparency is reduced by the damping supplied by the D term in the slave controller. For these experiments, we increased transparency beyond the normal limit, causing frequent unstable operation. Then the PC was added to provide transient stabilization when needed.

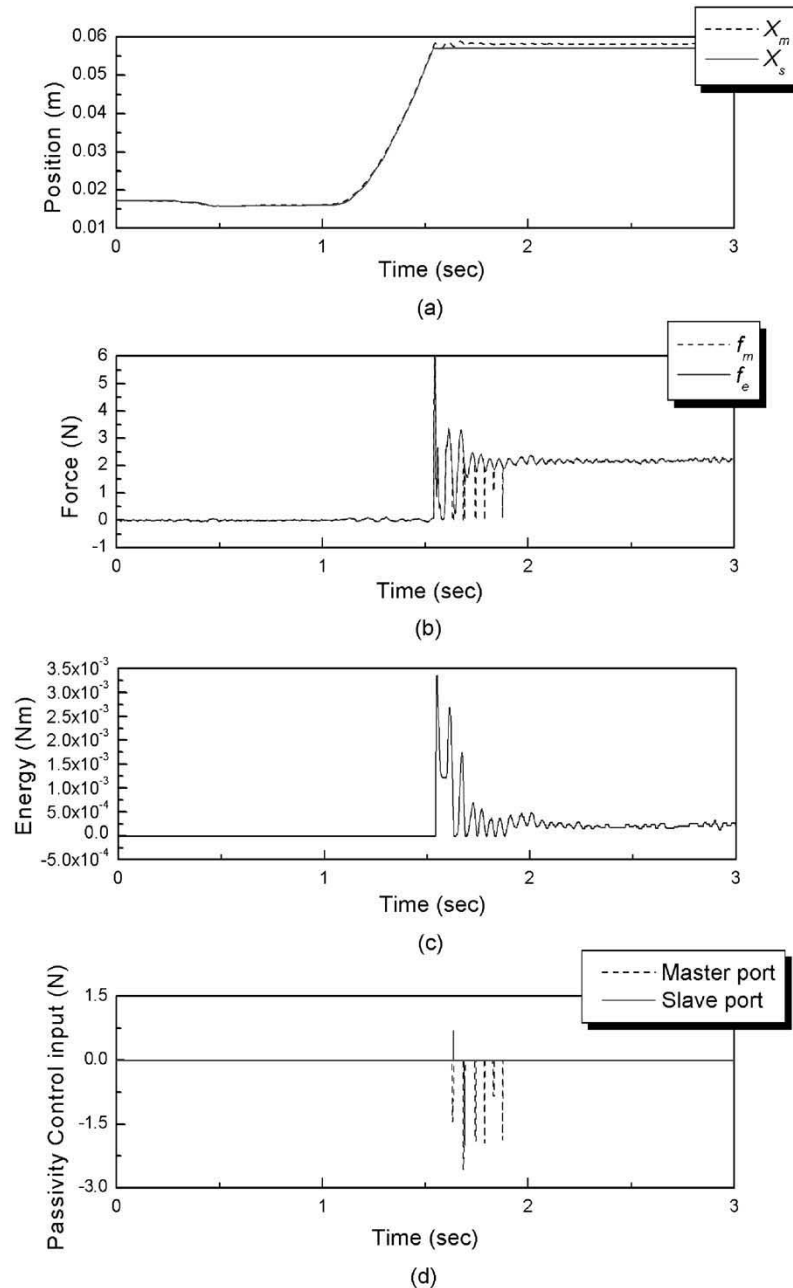

Fig. 9. Experimental results: hard contact with the same velocity as in Fig. 8 with series PC operating. Oscillation is suppressed by brief pulses of force from PC (bottom trace).

#### A. Contact With High Stiffness

In the first experiment, without the PC, the operator maneuvered the master to make the slave contact with the hard wall (approximately over 150 kN/m) with a relatively high velocity of about 120 mm/s. This resulted in an oscillation observable as force and position pulses [Fig. 8(a) and (b)]. The value of the PO was initially positive, but became increasingly negative with each contact [Fig. 8(c)]. Note that the initial bounce was passive, but from the second bounce, the system became active. Only  $X$ -directional signals are plotted, since the main interaction occurs on the  $X$  axis. The energy in Fig. 8(c) (and the following figures with suffix “c”) means net supplied energy to the bilateral controller and the PC, and this energy equals to the sum of the value of the PO and the dissipation amount of the PC ( $E_{\text{obsv}}(n) + \alpha_1(n)v_m(n)^2 + \alpha_2(n)v_s(n)^2$ ).

In the next experiment, with the PC turned on, the operator approached the contact point at the same velocity [Fig. 9(a)], but stable

contact was achieved with about seven bounces [Fig. 9(b)]. Again, the first bounce behaved passively, but subsequent smaller bounces were active [Fig. 9(c)]. On the second bounce, the PC at the master port began to operate [Fig. 9(d)], and eliminated the oscillation by modifying the master control force [Fig. 9(b)]. On the other hand, the PC at the slave port only operated on the second bounce [Fig. 9(d)]. Note that, even though the PC changes the master control force, the human can feel smoother force since the PC only operates very briefly at the end of contact, the PC changes the force with exactly that amount necessary to guarantee stability, and the force is filtered and transmitted to the human operator through the master mechanism.

#### B. Behavior During Low Velocity

In this subsection, we studied the behavior of the PC during low velocity. In this experiment, without the PC, the operator maneuvered

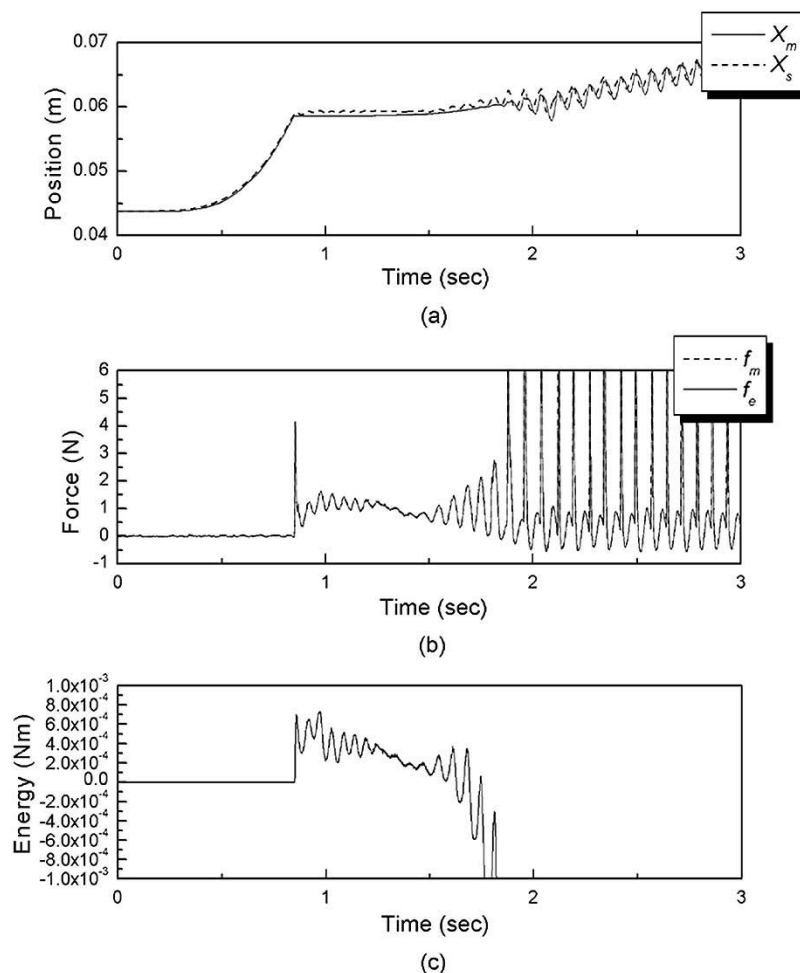

Fig. 10. Experimental results: hard surface following after slow contact. PC is inactive (bottom trace) and system exhibits sustained oscillations during the following.

the master to make the slave contact the hard wall at about 30 mm/s, and followed a slanted wall in the  $Y$  direction. Since the operator approached contact with relatively low velocity, stable contact and surface following is achieved before  $t = 1.5$  s. However, after  $t = 1.5$  s, the contact became unstable, resulting in an increasing oscillation [Fig. 10(a) and (b)]; the value of the PO remained positive before  $t = 1.5$  s, but became increasingly negative with each contact.

In the next experiment, with the PC turned on, the operator maneuvered the teleoperator in the same way, but a stable surface following [Fig. 11(a) and (b)] was achieved. The small force bounces before  $t = 1.7$  s can be seen to behave passively, but the following small force bounces were active. After  $t = 1.7$  s, the PC at the master and slave port began to operate [Fig. 11(d)], and eliminated the oscillation by modifying the transmitted force to the operator [Fig. 11(b)].

We also tested the system in contact with soft, sponge material. As expected, contact was stable in both cases. However, the value of the PO crossed to negative values for some very brief intervals (100–200 ms). Note that, although many applications of teleoperation involve hard contact, surgery application often involves contact with soft materials.

## VII. CONCLUSIONS AND FUTURE WORK

In this paper, the PO/PC was extended from one to two ports to ensure stable operation of the teleoperation system under a wide variety of

operating conditions. A general method for implementing the time-domain passivity-control scheme to teleoperation systems is proposed. Any existing teleoperation system, having arbitrary bilateral control architecture, can be stabilized with several additional lines of controller code. Design options exist for how to distribute energy dissipation for the case where energy is produced by two ports.

Since, to maintain stability, the PC only degrades performance (through the added damping of the PC) when it is needed, and only in the small amount needed, the performance can be maximized based on the guaranteed stability. Note that the proposed controller is not a method to increase performance (transparency), but a method to preserve performance while guaranteeing stability of a high performance system by adding the PO/PC to a conventional bilateral control scheme. The PC is expected to be very useful in teleoperation, since a known model or parameter estimation are not required.

There are several areas of future work that need to be pursued. The first issue is the identification of an external dissipation amount, and subsequently using it for the design of the PO/PC. In teleoperation systems, we need to estimate, in real time, the dissipation amount of the human/environment and master/slave mechanism that may allow the PC to operate with a different threshold, and thus, give even less conservatism.

In addition to the threshold problems, a method to apply the PO/PC to teleoperation systems with communication time delay must also be resolved. Due to the time delay, it is difficult to monitor the energy flow in and out of the bilateral controller in real-time software.

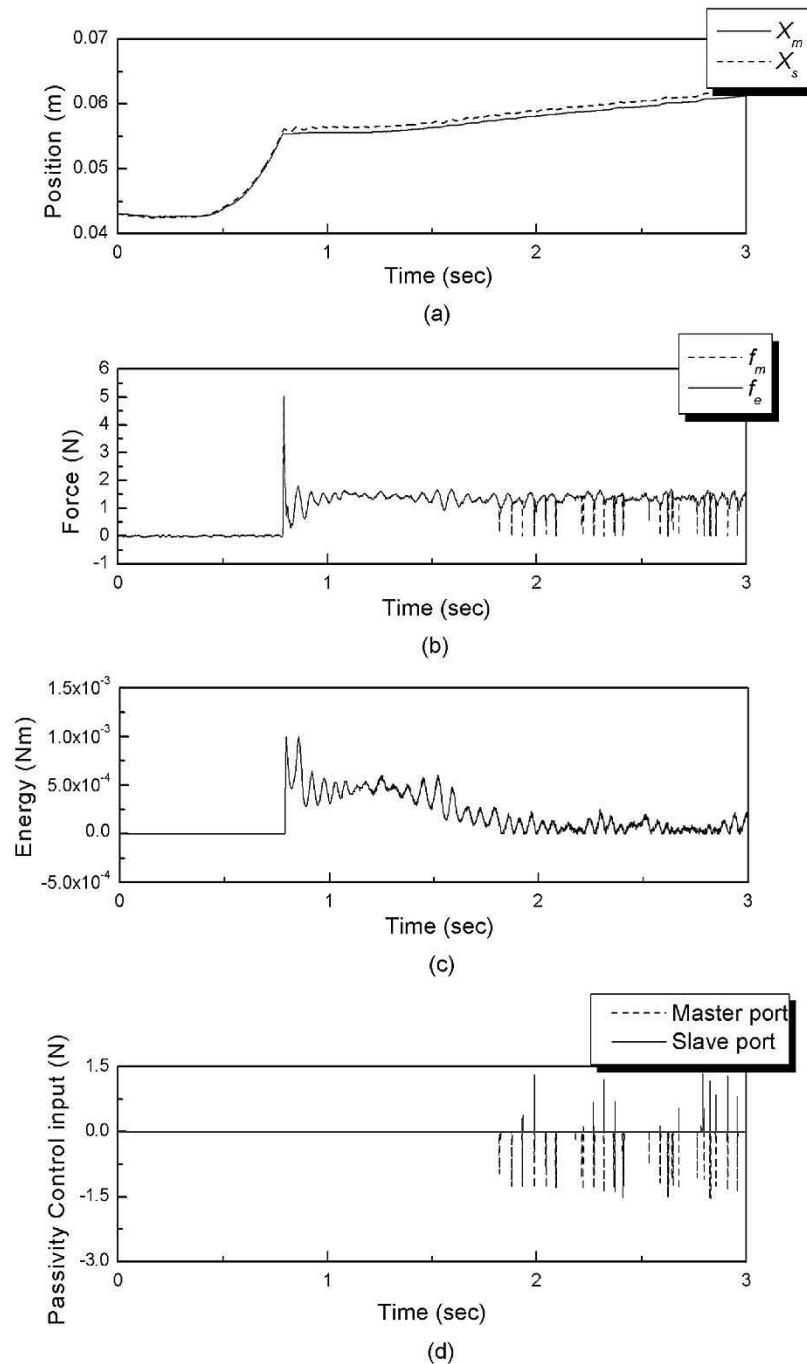

Fig. 11. Experimental results: hard surface following with the same way as Fig. 10. Oscillation is suppressed with the series PC (bottom trace).

#### REFERENCES

- [1] R. J. Adams and B. Hannaford, "Stable haptic interaction with virtual environments," *IEEE Trans. Robot. Automat.*, vol. 15, pp. 465–474, June 1999.
- [2] R. J. Anderson, "Autonomous, teleoperated, and shared control of robot systems," in *Proc. IEEE Int. Conf. Robotics and Automation*, Minneapolis, MN, 1996, pp. 2025–2032.
- [3] R. J. Anderson and M. W. Spong, "Asymptotic stability for force reflecting teleoperators with time delay," *Int. J. Robot. Res.*, vol. 11, no. 2, pp. 135–149, 1992.
- [4] J. E. Colgate, "Robust impedance shaping telemanipulation," *IEEE Trans. Robot. Automat.*, vol. 9, pp. 374–384, Aug. 1993.
- [5] J. E. Colgate and G. Schenkel, "Passivity of a class of sampled-data systems: Application to haptic interfaces," in *Proc. American Control Conf.*, Baltimore, MD, 1994, pp. 3236–3240.
- [6] C. A. Desoer and M. Vidyasagar, *Feedback Systems: Input-Output Properties*. New York: Academic, 1975.
- [7] B. Hannaford, "Design framework for teleoperators with kinesthetic feedback," *IEEE Trans. Robot. Automat.*, vol. 5, pp. 426–434, Aug. 1989.
- [8] B. Hannaford and J. H. Ryu, "Time-domain passivity control of haptic interfaces," *IEEE Trans. Robot. Automat.*, vol. 18, pp. 1–10, Feb. 2002.
- [9] N. Hogan, "Controlling impedance at the man/machine," in *Proc. IEEE Int. Conf. Robotics and Automation*, Scottsdale, AZ, 1989, pp. 1626–1631.
- [10] K. Hashtrudi-Zaad and S. E. Salcudean, "Adaptive transparent impedance reflecting teleoperation," in *Proc. IEEE Int. Conf. Robotics and Automation*, 1996, pp. 1369–1374.
- [11] —, "On the use of local force feedback for teleoperation," in *Proc. IEEE Int. Conf. Robotics and Automation*, 1999, pp. 1863–1869.



- [12] ———, "Analysis of control architectures for teleoperation systems with impedance/admittance master and slave manipulators," *Int. J. Robot. Res.*, vol. 20, no. 6, pp. 419–445, 2001.
- [13] H. Kazerooni and C. L. Moore, "An approach to telerobotic manipulations," *ASME J. Dynam. Syst., Meas., Contr.*, vol. 119, pp. 431–438, 1997.
- [14] D. A. Lawrence, "Stability and transparency in bilateral teleoperation," *IEEE Trans. Robot. Automat.*, vol. 9, pp. 624–637, Oct. 1993.
- [15] D. Lee and P. Li, "Passive coordination control for nonlinear bilateral teleoperated manipulators," in *Proc. IEEE Int. Conf. Robotics and Automation*, 2002, pp. 3278–3283.
- [16] ———, "Passive feedforward approach to the control of bilateral teleoperated manipulators," in *Proc. ASME Haptics Symp., IMECE*, 2000, pp. 1153–1160.
- [17] H. Lee and M. J. Chung, "Adaptive controller of a master-slave system for transparent teleoperation," *J. Robot. Syst.*, vol. 15, no. 8, pp. 465–475, 1998.
- [18] G. M. H. Leung, B. A. Francis, and J. Apkarian, "Bilateral controller for teleoperators with time delay via  $\mu$  synthesis," *IEEE Trans. Robot. Automat.*, vol. 11, pp. 105–116, Feb. 1995.
- [19] R. Lozano, N. Chopra, and M. W. Spong, "Passivation of force reflecting bilateral teleoperators with time-varying delay," in *Proc. Mechatronics*, Enschede, The Netherlands, June 2002, pp. 24–26.
- [20] G. Niemeyer and J. J. Slotine, "Stable adaptive teleoperation," *IEEE J. Oceanic Eng.*, vol. 16, pp. 152–162, Jan. 1991.
- [21] J. H. Ryu and D. S. Kwon, "A novel adaptive bilateral control scheme using similar closed-loop dynamic characteristics of master/slave manipulators," *J. Robot. Syst.*, vol. 18, no. 9, pp. 533–543, 2001.
- [22] S. E. Salcudean, "Control for teleoperation and haptic interfaces," in *Control Problems in Robotics and Automation*, B. Siciliano and K. P. Valavanis, Eds. New York: Springer-Verlag, 1997, vol. 230, Lecture Notes in Control and Information Sciences, pp. 50–66.
- [23] S. E. Salcudean, K. Hashtrudi-Zaad, S. Tafazoli, S. P. DiMaio, and C. Reboulet, "Bilateral matched-impedance teleoperation with application to excavator control," *IEEE Control Syst. Mag.*, vol. 19, pp. 29–37, June 1999.
- [24] A. J. Van der Schaft, *L2-Gain and Passivity Techniques in Nonlinear Control*. New York: Springer, 2000, Communications and Control Engineering Series.
- [25] J. C. Willems, "Dissipative dynamical systems—Part I: General theory," *Archive Rational Mech. Anal.*, vol. 45, pp. 321–351, 1972.
- [26] J. Yan and S. E. Salcudean, "Teleoperation controller design using  $H_\infty$  optimization with application to motion scaling," *IEEE Trans. Control Syst. Technol.*, vol. 4, pp. 244–258, Mar. 1996.
- [27] Y. Yokokohji and T. Yoshikawa, "Bilateral control of master-slave manipulators for ideal kinesthetic coupling-formulation and experiment," *IEEE Trans. Robot. Automat.*, vol. 10, pp. 605–620, Oct. 1994.
- [28] Y. Yokokohji, T. Imaida, and T. Yoshikawa, "Bilateral control with energy balance monitoring under time-varying communication delay," in *Proc. IEEE Int. Conf. Robotics and Automation*, San Francisco, CA, 2000, pp. 2684–2689.
- [29] W. Zhu and S. E. Salcudean, "Stability guaranteed teleoperation: An adaptive motion/force control approach," *IEEE Trans. Automat. Contr.*, vol. 45, pp. 1951–1969, Nov. 2000.